

AIRSYS

C A T A L O G

Optima2

Engineering Catalog



Contents

About Us	3
Optima2	4
Feature & Highlight	5
Overview	5
Efficiency	6
Modular Design	9
Reliability	10
Intelligent Control	11
Product Introduction	13
Model Identification	13
Blower Configurations	14
Cooling Configurations	14
Selected Features	15
Technical Specification	17
Unit Dimension Drawing	20
Clearance Drawing	27



About Us

At AIRSYS, we passionately believe that maintaining the climate of critical environments can be achieved through innovative, sustainable technologies, that will contribute to the preservation of Planet Earth.

Established in 1995, AIRSYS is a market leading solutions provider for the Telecoms, Data Centre, Medical and Utilities sectors, who think globally, but act locally. We deliver innovative, high efficiency precision control thermal solutions. With over 27 years' experience, combined with multiple manufacturing facilities and offices globally, AIRSYS is able to provide high quality, complete cooling solutions, including:



Design & consultation



Installation



Commissioning



Maintenance

Optima2

Optima2 is an innovative precision air conditioner designed for data centers, laboratories, equipment rooms and other mission critical applications.



Optima2 adopts vast number of cutting-edge technologies such as variable speed inverter compressor, variable speed EC fan, DFC direct fresh air free-cooling enabled control system. Its modular design will provide the maximum flexibility and scalability as well as the shortest cycle of production, delivery, and operation.



Feature & Highlight

Overview

Reliability



To guarantee the reliability in the IDC application, safe and stable running is the most primary and basic performance that Optima2 is committed to.

From components to design, from programming to control, from protection to verification, Optima2 provides all-round reliable performance as high as an IDC application could use. First class brands' components can realize a "Mean Time Between Failure" (MTBF) of greater than 100,000 hrs. Performance and electrical safety are fully tested while high level protection measures are designed to prevent any troubles arise from any possible causes.

The highest efficiency is achieved by amazing system design, top-ranking components, and pioneer control system. With the aim of PUE under 1.1, Optima2 is given extraordinary function to contribute to the great green plan of saving the energy resource.

To quantitative evaluate the efficiency, Optima2 achieves the Net Sensible Cooling COP values based on AHRI standard which is contributed to the technology applied on Optima2 and the excellent components (Inverter compressor/ EC fan/ EEV/DFC) built into the system.

Efficiency



Modular Design

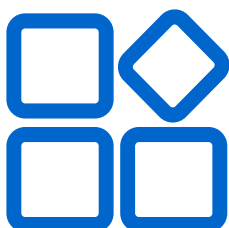

Optima2 adopts the modular design concept, with only one standard module, customers could configure up to 16 modules per multi-unit controller with cooling capacity ranging from 20 – 640kW.

Genuine modularity not only enables great flexibility and scalability to the customer but also shortens the lead time to great extent combing with the standardized model's management.

With the small footprint, modules can be easily combined and installed without taking much space.

With equipped with a full automatic control system and the 'mind' given to it, Optima2 can conduct self-diagnosis, react and cope with various situations, communicate with user and other units and deliver prominent energy efficiency.

Intelligent Control



Efficiency

pUE

Optima2 is designed and manufactured to deliver the best-in-class PUE performance in the industry.

PUE stands for Power Usage Effectiveness; it is widely used to measure the overall energy efficiency of a datacenter (facility).

$$PUE = \frac{\text{Total Datacenter Energy Consumption}}{\text{IT Equipment Energy}}$$

Optima2

Compressor	Inverter	Digital Scroll ¹⁾	Fixed Speed
Fans²⁾	EC	EC	EC
Free cooling³⁾	Direct fresh air (DFC)	Refrigerant Pump	Glycol chilled water
Cooling PUE	1.05-1.10	1.15-1.20	1.20-1.30
Annual Cooling Energy Consumption⁴⁾	26,280	61,320	87,600

- Digital compressor is using on/off bypass valve to regulate the refrigerant flow, not the compressor motor speed.
- Fans including both indoor and outdoor units
- Free cooling is an optional feature.
- kWh @ 40kW IT load
- Ambient temperature data refers to New York

Technology & Components

Inverter Compressor

High Efficiency: An A/C will operate with partial load at most of the time, therefore keeping the compressor running at lower speed will result in an exponential reduction of energy consumption. In addition, the lower refrigerant flow in the circuit will increase the heat-exchange efficiency.

Precise Control: Comparing to a fixed-frequency compressor, an inverter compressor can achieve more precise temperature control up to $\pm 0.2^{\circ}\text{C}$ ($\pm 0.5^{\circ}\text{F}$) at a variable load condition, even when the load is constantly changing. See below Graph shows the difference between variable and fixed speed compressor control.

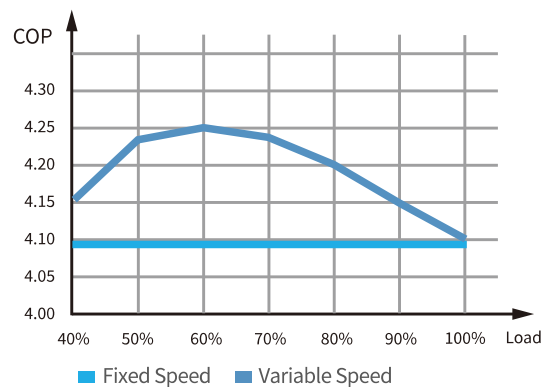
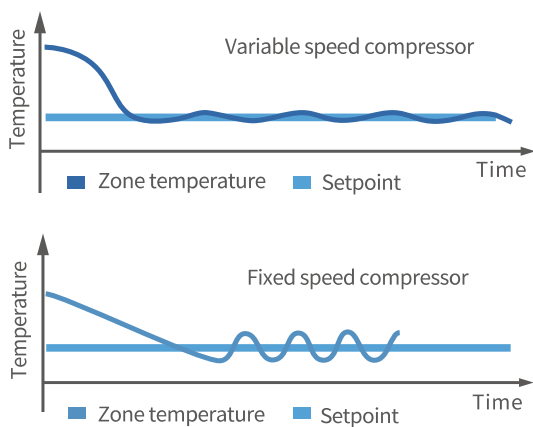

Lower Noise: 5-10 dB lower due to the partial operation mode.

Low Starting Current: an inverter compressor starting current is only about 10% of that of the fixed speed compressor.

Longer compressor life: by eliminating the frequent start/stop of the compressor, the life cycle will be significantly prolonged and failure rate will be reduced.

EC fan

Energy Efficiency: The electronic commuted motor could reach 85-90% of efficiency which is 30% higher than traditional motors' 65-70%. On top of that, when the fan is operating in lower speed, the saving will be exponential. See graph.

Airflow Management: all EC fans are intelligent, with integrated control module. Together with external sensors and control system, the fan(s) could deliver the exact amount of air flow and pressure needed without over-performing to consume excessive energy.

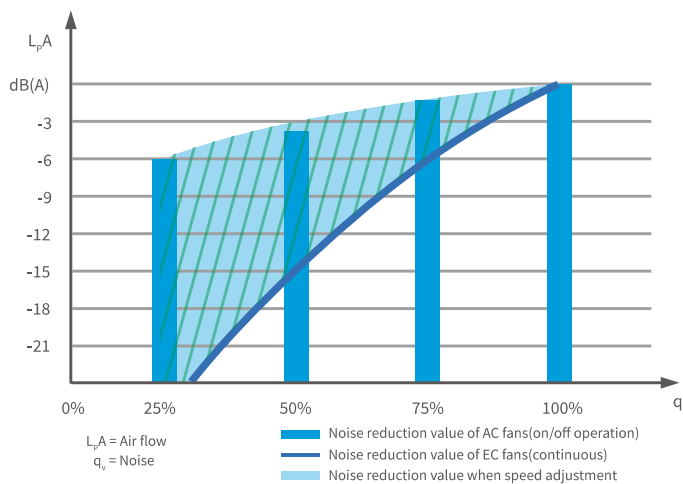
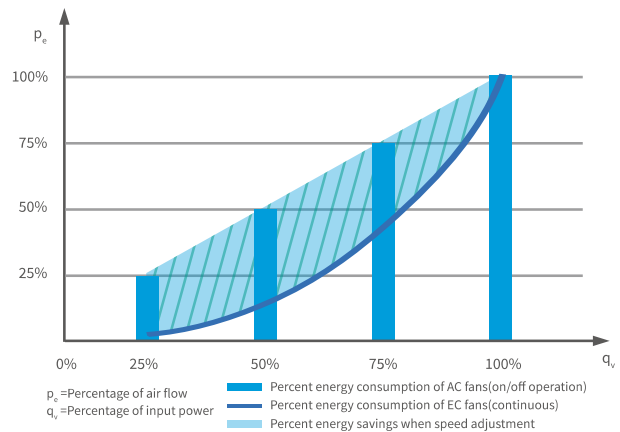

Lower Noise: At lower speed, the EC fans will have much lower noise level than at its maximum speed. In the graph, the bars indicate the sound pressure level of fans which are switched in as can be seen from the picture EC fan sound pressure level is 12dB lower compared to the traditional AC fan.

DFC -Direct Fresh Air Economizer (Optional)

Among all the available free-cooling technologies on the market, Fresh Air Free-cooling is recognized as the most effective, reliable, and efficient solution. Optima2 DFC is designed to offer a fully integrated Fresh Air Free-cooling Option with following features:

Easy installation: The DFC module could be easily installed behind the Optima2 units whenever there is direct access to ambient air through walls. It will only slight increase the overall footprint, see graph.

Supply air temperature and humidity control: with the damper on both DFC and Optima2 module, the fresh air and return air will be mixed to regulate the supply air temperature. The DFC will be shut-off when ambient temperature is too high and free-cooling is not adaptable.

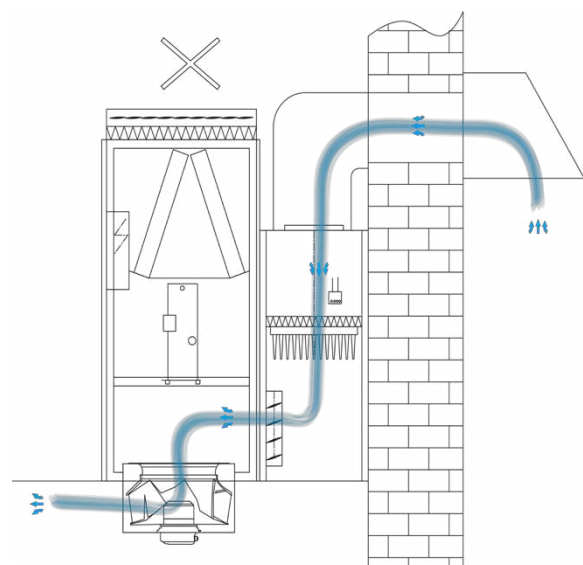

Hybrid cooling mode: The hybrid cooling mode will allow both the DFC and compressor running when ambient temperature is lower than return air temperature. This will maximize the energy saving.

Easy maintenance: The filter and fan could be replaced from the side of the DFC module.

AFPD (optional): Airsys proprietary dust sensor will allow the DFC to be shut-off when the dust or other particle level is high, which will protect the filter from pollution and prolong the maintenance interval.

Humidifier (optional)

Electrode humidifier: using electrode to boil the water into clean steam. It regulates the humidification capacity by the electric current (water level in the cylinder).

Ultrasonic humidifier: this humidifier is the most energy efficient solution, with only 10% of energy consumption as the Electrode or Infrared humidifier. It must be installed in the air flow path, e.g., under the raised floor, or inside the air discharge duct.

*Note: Electrode humidifier is a built-in humidifier and ultrasonic humidifier is an external humidifier which is controlled by A/C.



1.0 μm

Dimension: Technology to atomize water into fine droplets which dimension is down to 1.0 u and absorb them instantaneously by the airflow.



10 %

Power Consumption: Ultrasonic humidifiers ensure that tiny water droplets evaporate naturally in the environment. Absorbs energy from the air to change the state of matter, thereby cooling the air, saving 90% energy compared to steam humidifier.

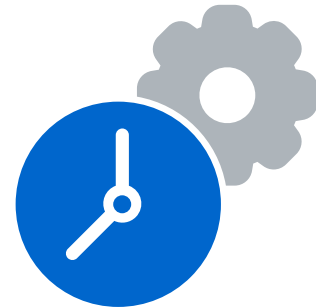

10 k

Operation Running Hours: Continuous operation for 10,000 hours is guaranteed, which means that it has extremely low maintenance rate and is a reliable solution for critical applications.

Modular Design

Optima2 adopts the modular design concept, with only one standard module. Customers could configure up to 16 modules into one unit with cooling capacity ranging from 20 – 640kW. The configuration could be done at all stages of the project, giving great flexibility and scalability to the customer.

Sample Configurations:

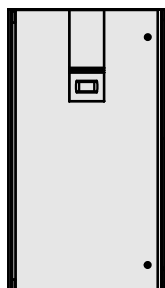

20~40kW

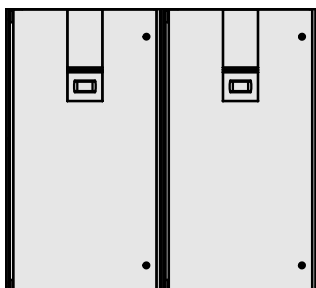

40~80kW

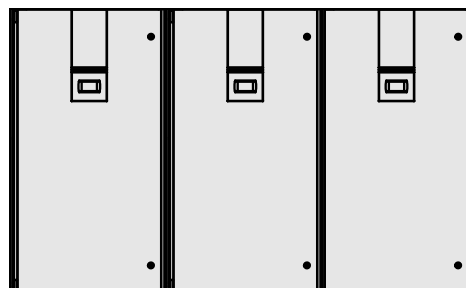

60~120kW

Flexibility

Modules could be installed side by side, with up to 16 modules to be configured per multi-unit controller

A unit with more than 1 module has an individual display on each module which provide better visibility for each module's performance. All the modules of the same unit will work synchronously such as compressor and fan speed.

In the way, the unit cooling capacity is purely configured through software, and it would be possible to change the configuration of unit on site according to the heat load or air management requirement. This will give the customer all the flexibility to optimize the capacity and air flow to achieve the best cooling performance and energy efficiency.

Scalability

Optima2 allows scalability for future growth, as well as the ability to efficiently add redundant units for maximum reliability in the most mission-critical applications.

Easy Installation

Modular design allows easy move and handling for installation, especially for those retrofitting projects where limited pathway and lift space become the bottleneck hence increase the cost of installation significantly.

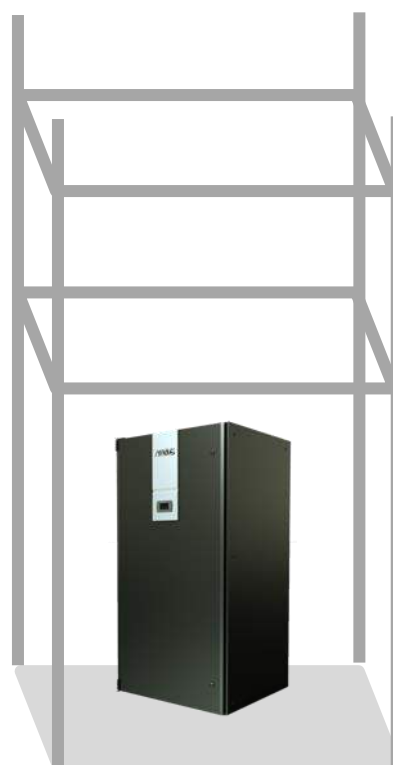
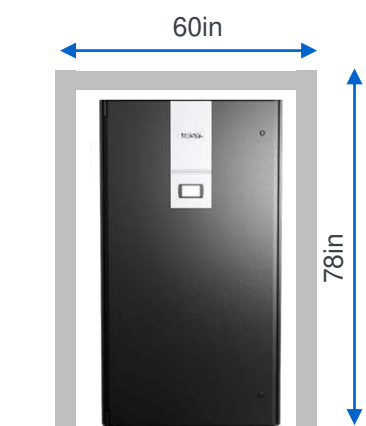

Maintenance

The Module is fully front accessible for operation and maintenance. All the major components could be easily replaced on site.

Small Footprint

	Cooling Capacity (kW)	Size L×W×H (in)	Foot Print (ft ²)	Cooling Density(kW/ft ²)
AIRSYS	40	43×39×78	11.6	3.45
Comparable	40	77×35×76	18.7	2.67

Lead time

Highly standardized material and component will allow the efficiency of supply chain management. No matter it's related to product lead time, spare parts handling as well as technical support and service.

Reliability

Onboard best in class components from around the world, the Optima2 system can realize a “Mean Time Between Failure” (MTBF) of greater than 100,000 hrs.

Optima2 is equipped with the latest VFD inverter technology that drastically reduces compressor wear and tear caused by the constant “start / stop” repetitive cycles. High reliable EC fan makes that air flow will not be lower than 90% of design air flow even when the pressure drop reaches as high as 250Pa (1 in. H₂O). The inverter compressor cooperating with EC fan working at a various speed that regulates according to the actual IT load guarantees utmost efficiency and reliability.

In addition, automatic economizer transition (DFC) maximizes economizer run time and minimizes wear and tear on compressors.

Protection

Cooling capacity back up

Modularization allows mutual backup between modules which enhances the ability of eliminating the impact of an unplanned outage or failure on computer equipment.

Voltage Protection-Control Protection

There is a voltage relay for protection. When the supply voltage is over the permitted range, the unit will be stopped.

For 3 phase units, if there is phase unbalance or phase absence, the unit will also be stopped for protection.

Alarm Precaution

- Heater alarm
- Supply fan overload alarm
- Filter clogged alarm
- Fire and smoke alarm
- Overload/thermal protection of supply fan
- Indoor temperature & humidity high/low
- System/ main components failure
- Communication failure
- Mechanical refrigeration failure

Intelligent Control

Modular Control

Optima2 is a modular design unit with 40kW basic modular which can be parallelly connect up to 16 modules in a single system to achieve a combined system with 20~640kW cooling capacity. Each Optima2 module is equipped with an individual controller and display allowing redundancy and control the system independently and check the operation status for each modular unit separately.

Fully Automatic Control

The unit is equipped with a fully automatic control system to manage temperature and relative humidity levels according to the default setpoint defined by users. All control, protection, alarm functions are automatic with auto-restart.

Working Mode Auto-Alternated

The unit automatically selects between mechanical cooling, free cooling modes when DFC option is equipped; Humidity control will automatically initiate when it requires.

Mechanical Cooling Mode

Room temperature control with variable speed compressor and fans

Free Cooling Mode (Optional)

In the event of either electrical or mechanical failure affecting the refrigeration system, the unit will be capable of automatic reversion to the fresh air cooling mode.

Humidity Control – Dehumidification

Dehumidification mode starts with compressor running at low speed when the room RH is higher than setpoint.

Humidity Control – Humidification (Optional)

Humidifier turns on when the room RH is lower than setpoint.

Automatic Self-Diagnosis

All the components connected to microprocessor are continuously tested. In case of malfunction, the failure is shown on the display with relevant information.

Running Data Logging

The controller has a memory of 2M for data logging. If the interval of data logging is less than 5 minutes, the controller can store at least 48 hours working data.

The Ethernet interface is standard configuration which enable automatic download of full logs. The format of the data should be CSV or Excel file.

Remote Network Monitoring System

RS485 and Ethernet interface is standard configuration which allows Modbus RTU and Modbus TCP/ IP protocol. Ethernet interface provides availability of FTP, HTTP and SNMP (SNMP is an option required ordered individually).

Each controller supports web server function for remote control and monitoring via Ethernet network by using a web browser. Balance all modules working time automatically. If there are more than two modules installed, the controller will alternate the working module automatically according to the total working time of the units to balance the working time.

Multi-system and Multi-zone Control

Multi-system and multi-zone adopt flexible combination mode, which can realize the combined control of different systems in the same region or different regions.

OP2MUC- the multi-system controller achieves up to 4 different Zones assignment control with multiple systems (One master and up to 16 modules in different zones). All modules working status can be viewed through OP2MUC, with different backup and redundancy options available depending on project requirements.

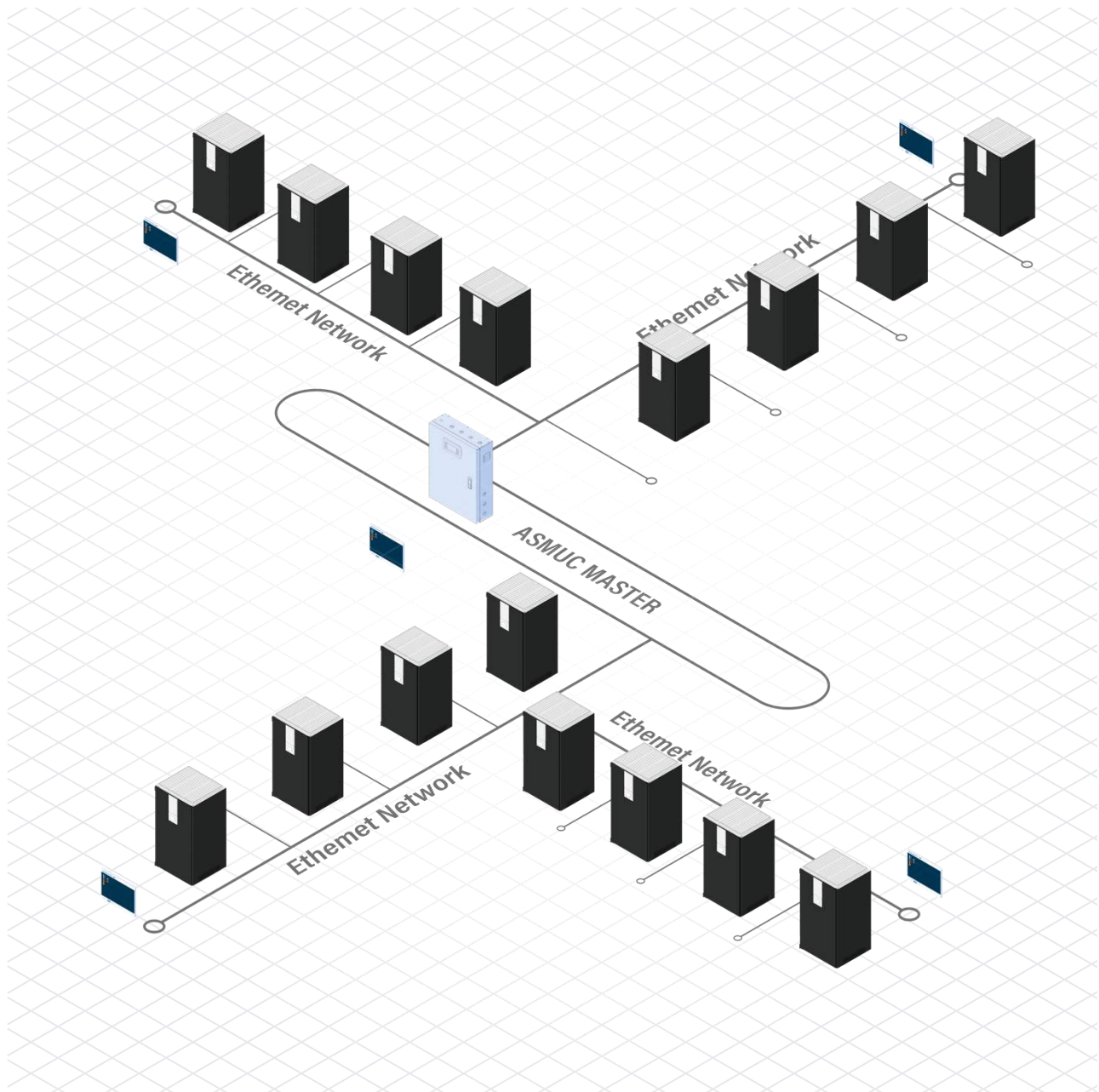

Control algorithm based on temperature and optionally on air pressure differential, whose priority depends on customer's demand.

Product Introduction

Model Identification

01	02	03	04	05	06	07	08	09	10	11	12	13	14	15	16	17	18
	OP2		A	X		040		V	1	D	1	A	C	-	S	T	X

01-03	OP2	Model Series: OP2 – Optima2 precision air conditioner, abbr. as OP2
04	A	Cooling Method: A – Air Cooled
05	X	Free Cooling Options X – Standard D – Direct Free Cooling
06-08	040	Capacity: 040 – 40kW
09	V	Compressor: V – Inverter Compressor
10	1	Number Of Compressor: 1
11	D	Cabinet Type T – Top Flow D – Down Flow
12	1	Number Of Cabinets: 1
13	A	Refrigerant: A – R410A
14	C	Power Source B – 208~230V/3PH/60Hz C – 460V/3PH/60Hz
15	-	Separator
16	S	Heater Option in Each Cabinet X – Standard S – 6kW Electrical Heater N – 9kW Electrical Heater
17	T	Humidifier Option in Each Cabinet X – Standard T – 3kg/6.6lbs per hr Steam Humidifier V – 8kg/17.6lbs per hr Steam Humidifier F – 4kg/8.8lbs per hr Infrared Humidifier U – 4kg/8.8lbs per hr External Ultrasonic humidifier
18	X	Custom Option X – Standard

For Example:

OP2AX040V1D1AC-SVX

40kW Standard unit, 1 compressor, down flow, R410A, 460V/60Hz/3PH, 6kW heater and 3kg/6.6lbs electrode humidifier.

Blower Configurations

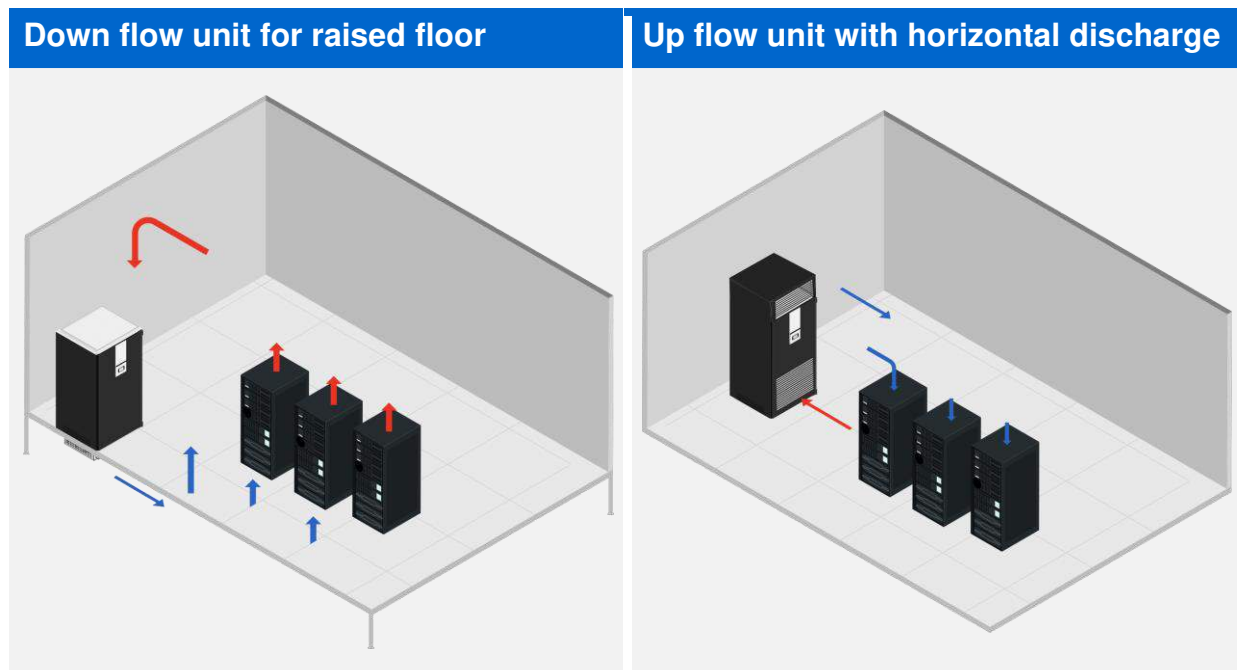

Cooling Configurations

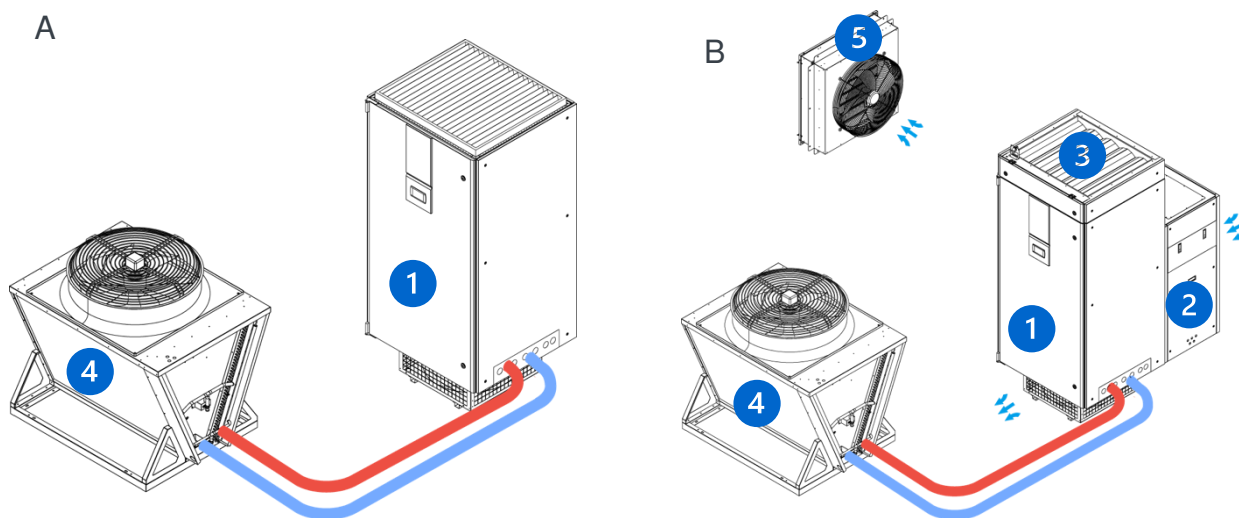

Item	Description
A	Air-Cooled direct expansion cooling system with all standard features
B	Air-Cooled direct expansion cooling system with all standard features and DFX option (Economizer) which allows to bring in the fresh air when the outdoor temperature is cool enough.
1	Optima2 precision air conditioner
2	DFC fresh air inlet plenum
3	Return air plenum
4	VMEG Condenser
5	Exhaust damper & fan

Selected Features

	Standard Top Flow	Standard Down Flow	DFC Top Flow	DFC Downflow
EC Fan	●	●	●	●
Inverter Scroll Compressors	●	●	●	●
Electronic Expansion Valves	●	●	●	●
High Efficiency, Aluminum Fin/Copper Tube Coils	●	●	●	●
Galvannealed Steel, Powder Coated Finish	●	●	●	●
Stainless Steel Condensate Drain Pan	●	●	●	●
3/5" non-flammable Thermal & Sound Insulation	●	●	●	●
R410 Refrigerant	●	●	●	●
Refrigerant Sight Glasses and Filter Drier	●	●	●	●
Air Filter				
MERV 8 (G4)	●	●	○	○
MERV 13 (F7)	○	○	●	●
Adjustable Floor Stand (18in)	○	○	○	○
Adjustable Floor Stand (21in)	○	○	○	○
Adjustable Floor Stand (24in)	○	○	○	○
Adjustable Floor Stand (30in)	○	○	○	○
Condensate Pump with Overflow Switch	○	○	○	○
Backdraft Damper	○	/	○	/
Free Discharge Plenum	○	/	○	/
Supply Air Plenum	/	○	/	○
Temperature Control				
VFD Cooling Mode	●	●	●	●
Electric Heating	○	○	○	○
Low Ambient Cooling (-20F)	●	●	●	●
Low Ambient Kit (-20F~-40F)	○	○	○	○
Heating Control				
Electrical Heater				
6kW Electrical Heater	○	○	○	○
9kW Electrical Heater	○	○	○	○
Humidity Control				
Electrode Humidifier				
6.6lbs/hr Electrode Humidifier	○	○	○	○
17.6lbs/hr Electrode Humidifier	○	○	○	○
Infrared Humidifier				

● Standard ○ Optional / Not Available

8.8lbs/hr Infrared Humidifier	<input type="radio"/>	<input type="radio"/>	<input type="radio"/>	<input type="radio"/>
Ultrasonic Humidifier (External)				
17.6lbs/hr Ultrasonic Humidifier	<input type="radio"/>	<input type="radio"/>	<input type="radio"/>	<input type="radio"/>
Dehumidification Mode	<input checked="" type="radio"/>	<input checked="" type="radio"/>	<input checked="" type="radio"/>	<input checked="" type="radio"/>
Control System				
Touchscreen Display	<input checked="" type="radio"/>	<input checked="" type="radio"/>	<input checked="" type="radio"/>	<input checked="" type="radio"/>
Single Module Control	<input checked="" type="radio"/>	<input checked="" type="radio"/>	<input checked="" type="radio"/>	<input checked="" type="radio"/>
Group Control (Multiple Modules)	<input type="radio"/>	<input type="radio"/>	<input type="radio"/>	<input type="radio"/>
Supply Air Temperature Sensor	<input type="radio"/>	<input type="radio"/>	<input type="radio"/>	<input type="radio"/>
Remote Webpage	<input checked="" type="radio"/>	<input checked="" type="radio"/>	<input checked="" type="radio"/>	<input checked="" type="radio"/>
SNMP/IP	<input checked="" type="radio"/>	<input checked="" type="radio"/>	<input checked="" type="radio"/>	<input checked="" type="radio"/>
BACnet/IP	<input type="radio"/>	<input type="radio"/>	<input type="radio"/>	<input type="radio"/>
Lockable Disconnect Switch	<input checked="" type="radio"/>	<input checked="" type="radio"/>	<input checked="" type="radio"/>	<input checked="" type="radio"/>
Floor Water Detection	<input checked="" type="radio"/>	<input checked="" type="radio"/>	<input checked="" type="radio"/>	<input checked="" type="radio"/>
Energy Monitoring	<input type="radio"/>	<input type="radio"/>	<input type="radio"/>	<input type="radio"/>
Automatic Transfer Switch	<input type="radio"/>	<input type="radio"/>	<input type="radio"/>	<input type="radio"/>
Floor Supply Air Pressure Sensor	<input type="radio"/>	<input type="radio"/>	<input type="radio"/>	<input type="radio"/>
Safety Features/Alarm				
Filter Alarm	<input checked="" type="radio"/>	<input checked="" type="radio"/>	<input checked="" type="radio"/>	<input checked="" type="radio"/>
HP/LP alarm	<input checked="" type="radio"/>	<input checked="" type="radio"/>	<input checked="" type="radio"/>	<input checked="" type="radio"/>
Indoor temperature & humidity high/low	<input checked="" type="radio"/>	<input checked="" type="radio"/>	<input checked="" type="radio"/>	<input checked="" type="radio"/>
Fire/smoke alarm	<input checked="" type="radio"/>	<input checked="" type="radio"/>	<input checked="" type="radio"/>	<input checked="" type="radio"/>
System/ main components failure	<input checked="" type="radio"/>	<input checked="" type="radio"/>	<input checked="" type="radio"/>	<input checked="" type="radio"/>
Remote on/off	<input checked="" type="radio"/>	<input checked="" type="radio"/>	<input checked="" type="radio"/>	<input checked="" type="radio"/>
DFC Options				
DFC Plenums	/	/	<input checked="" type="radio"/>	<input checked="" type="radio"/>
Motorized Exhaust Damper	/	/	<input type="radio"/>	<input type="radio"/>
Exhaust Fan	/	/	<input type="radio"/>	<input type="radio"/>
Dust Alarm (AFPD)	/	/	<input checked="" type="radio"/>	<input checked="" type="radio"/>
Regulation				
AHRI-1360	<input checked="" type="radio"/>	<input checked="" type="radio"/>	<input checked="" type="radio"/>	<input checked="" type="radio"/>
ETL-UL 60335& CSA C22.2	<input checked="" type="radio"/>	<input checked="" type="radio"/>	<input checked="" type="radio"/>	<input checked="" type="radio"/>
Packaging				
Honeycomb Packaging	<input type="radio"/>	<input type="radio"/>	<input type="radio"/>	<input type="radio"/>
Wooden Crate	<input checked="" type="radio"/>	<input checked="" type="radio"/>	<input checked="" type="radio"/>	<input checked="" type="radio"/>

● Standard ○ Optional / Not Available

Technical Specification

Modular Unit DXA Performance Data

Nominal Data

Model		DXA40V1X0
Power Source		460/3/60
Air Flow Scheme (1)		Top Flow/Down Flow
Net DX Cooling Capacity-85F 50% /95 OD		
Max. Cooling Capacity	kW(BTU/h)	43.0 (146,700)
Min. Cooling Capacity	kW(BTU/h)	20.0 (68,200)
Total Cooling Capacity	kW(BTU/h)	40.8 (139,200)
Sensible Cooling Capacity	kW(BTU/h)	40.0 (136,500)
Evaporator Section		
Supply Fan type(Qty.)		EC Backward Centrifugal
Fan Qty.	n.	1
Air Volume	m3/h(CFM)	10,850 (6,390)
ESP	Pa (In H2O)	100 (0.4)
Power Consumption	kW	2.1
Current	A	3.17
Coil Rows/Face Area	Rows/ft2	5 /14.97
Face Velocity(fpm)	fpm	427
Filter		
Type	Plate filter	
MERV Rating (Standard/Optional)	MERV 8 Standard	MERV 13 Optional
Nominal Size × Qty.	36.8 × 33.8 × 4" (Top Flow) 38.8" × 34.8" × 2" (Down Flow)	

Modular Unit DXA Performance Data

Nominal Data-Continue

Model		DXA40V1X0	
Power Source		460/3/60	
Air Flow Scheme (1)		Top Flow/Down Flow	
Compressor			
Type		Inverter Scroll	
Qty.		1	
Nominal Power Consumption	kW	9.4	
Nominal Current	A	14	
Max. Power Consumption	kW	16.9	
Max. Current	A	24	
Electrical Heater (Optional)			
Type			
Capacity	kW	6	9
Current	A	7.5	11.3
Working Step	n.	2	2
Connection Size			
Humidifier water supply Φ	in	1/2"	
Condensate water drainage Φ	in	3/4"	
Refrigerant discharge	in	1"	
Refrigerant liquid	in	3/4"	
Dimension			
Unit Dimension H×W×D	In × in × in	77.76" × 42.91" × 38.98"	
Approximate Unit Weight	lb	893	
Package Dimension H×W×D	In × in × in	84.26" × 46.85" × 4 2.92"	
Approximate Package Weight	lb	1003	

Variable Working Condition

Net DX Cooling Capacity @ OD Ambient Temperature 95F Includes DX evaporator motor heat @ std CFM and ESP	ID 75F DB RH44% 52F DP		ID 85F DB RH32% 52F DP		ID 95F DB RH23% 52F DP	
	kW	BTU/h	kW	BTU/h	kW	BTU/h
Max. Cooling Capacity	40.0	136,540	43.0	146,760	50.0	170,650
Min. Cooling Capacity	18.0	61,400	20.0	68,260	22.0	75,080
Total Cooling Capacity	36.0	122,860	40.0	136,500	40.0	136,500
Sensible Cooling Capacity	34.0	116,040	39.2	133,780	39.4	134,470
NSenCOP	2.5		3.2		3.55	

Net DX Cooling Capacity @ ID Room Temperature 85F Includes DX evaporator motor heat @ std CFM and ESP	OD 95F		OD 80F		OD 65F		OD 40F	
	kW	BTU/h	kW	BTU/h	kW	BTU/h	kW	BTU/h
Max. Cooling Capacity	43.0	146,760	47.0	160,360	48.0	163,780	50.0	170,600
Min. Cooling Capacity	20.0	68,260	23.0	78,480	24.0	81,890	25.0	85,300
Total Cooling Capacity	40.0	136,500	40.0	136,500	40.0	136,500	40.0	136,500
Sensible Cooling Capacity	39.2	133,780	39.5	134,770	39.5	134,770	39.5	134,770
NSenCOP	3.2		3.98		4.8		6.1	

Air Volume @ Different EPS

Air Volume @ different EPS @ Nominal Power Consumption							
EPS	Pa /(In H ₂ O)	20(0.08)	50 (0.2)	75(0.3)	100(0.4)	150(0.6)	200(0.8)
Air Volume	m ³ /h	12,000	11,700	11,350	10,950	10,000	9,000
	SCFM	7,068	6,891	6,685	6,450	5,890	5,301
Power Consumption	kW	1.96	2.01	2.06	2.06	2.10	2.10

Electrical Data

Heater Config		0kW			6kW	9kW
Humidifier Config		None	Infrared, Ultrasound, or 6.6lbs/hr Steam	17.6lbs/hr Steam	All	All
Power Source		3-460V/3Ph/60HzH				
Max. Op Power	kW	25.3	27.6	31.3	34.3	31.3
Max. Op Current	A	37	40.1	44.5	48.5	44.5
MCA	A	45	52	52	57	52
MOP	A	70	70	70	80	70

Unit Dimension Drawing

Modular Unit

Cabinet Dimension Drawing for Down Flow Unit

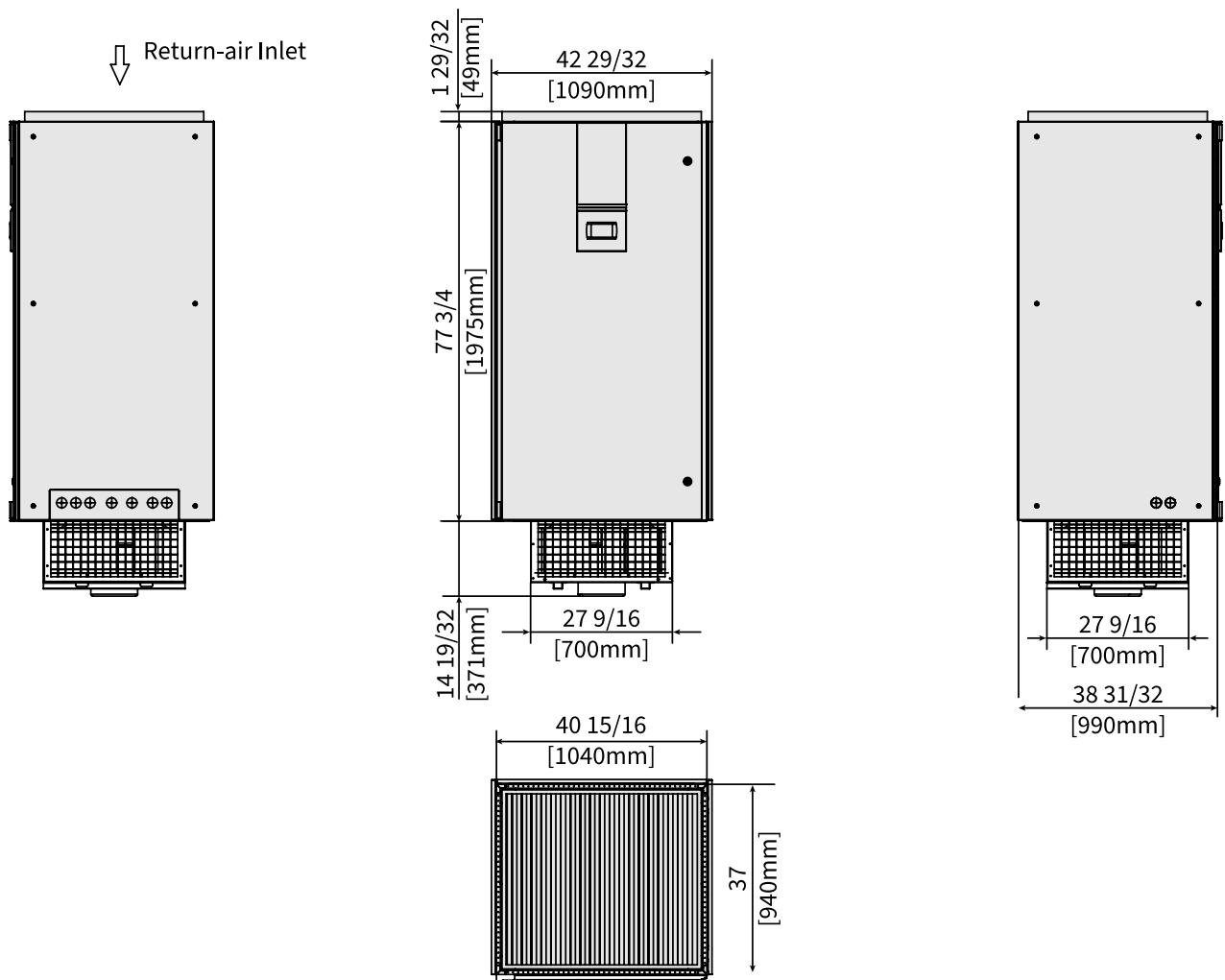

Cabinet Dimension Drawing for Top Flow Unit

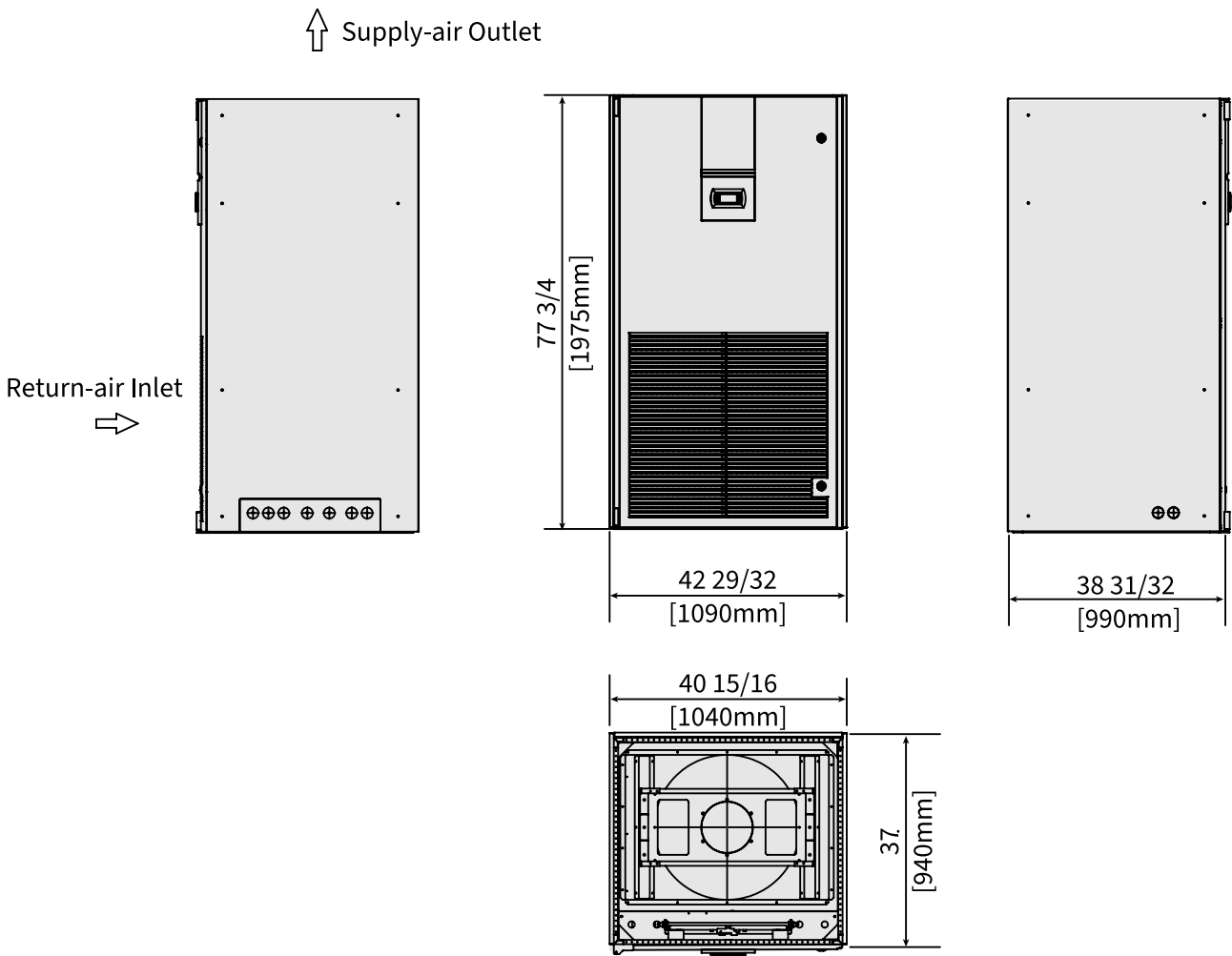

Optima2-Outdoor Condenser Dimension Drawing

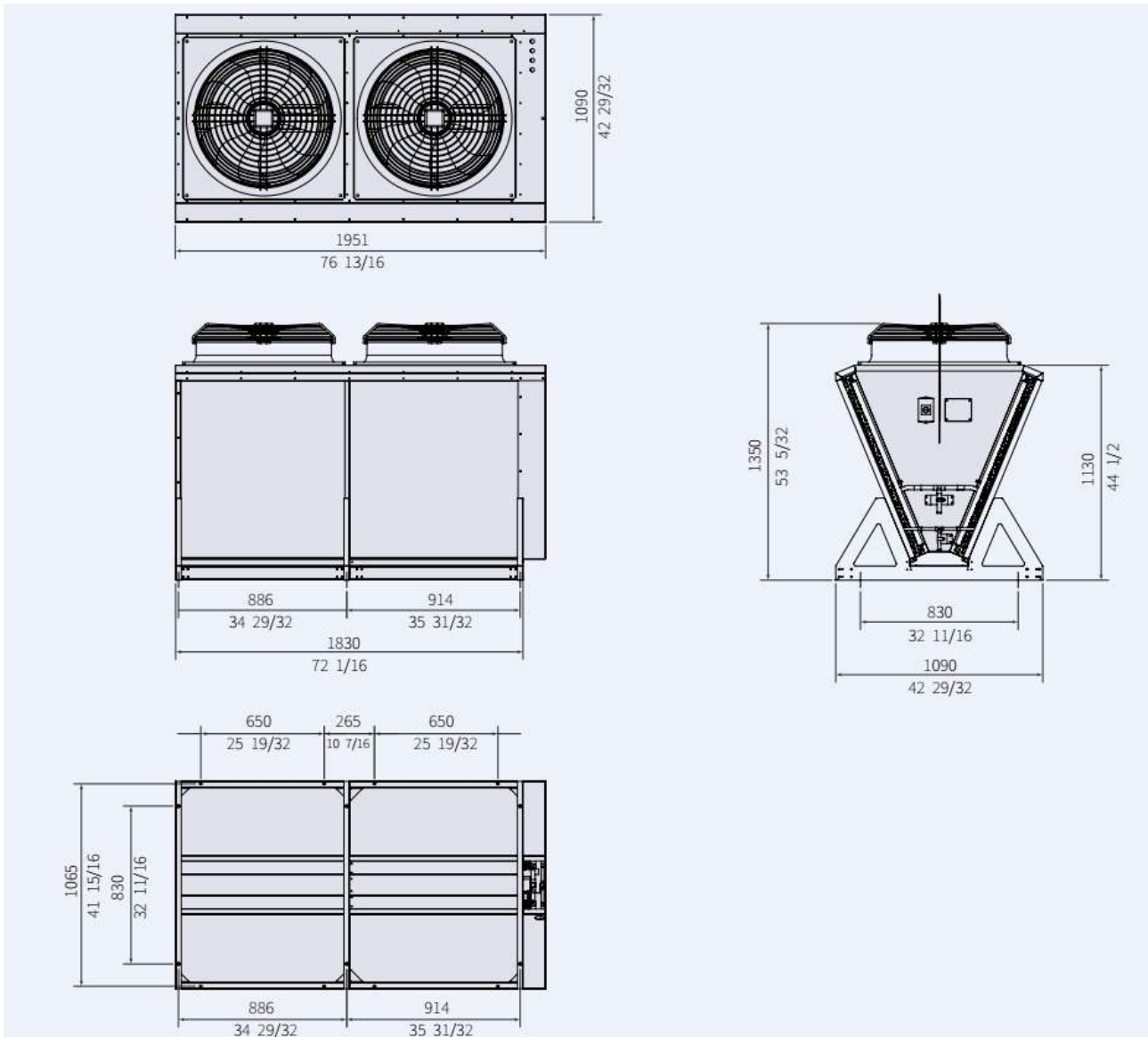

Optima2-DFC Fresh Air Inlet Box Dimension Drawing

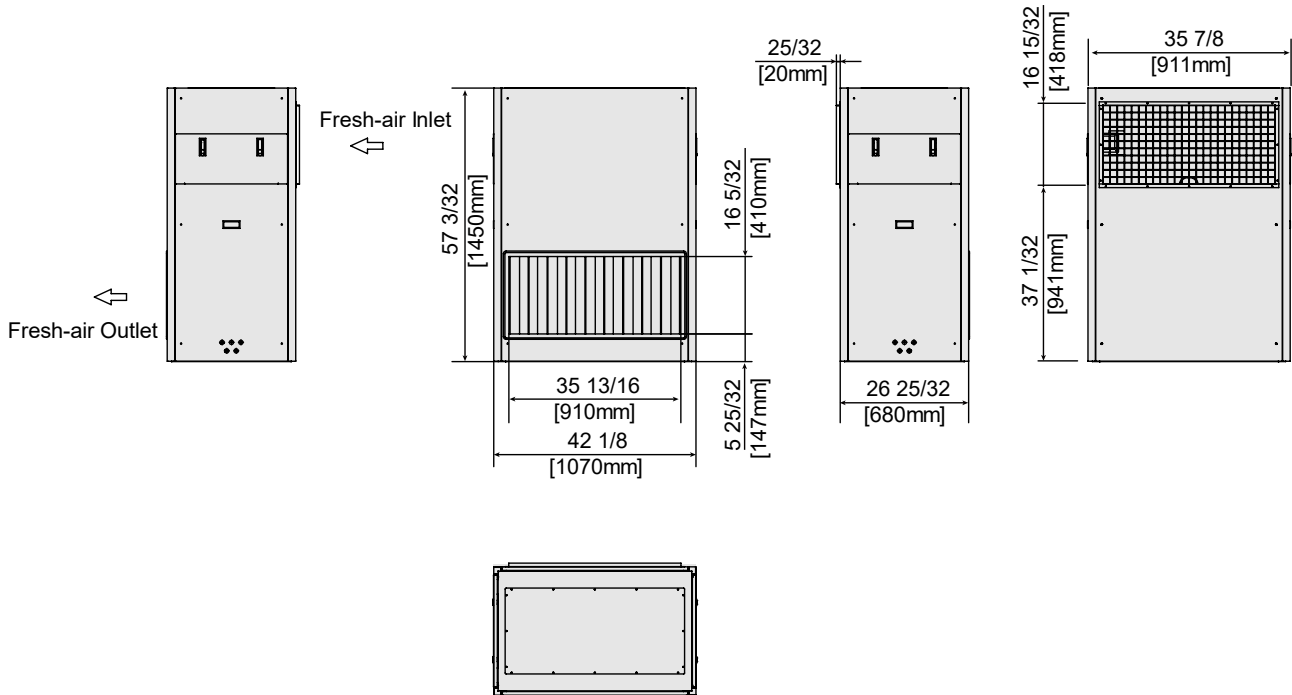

Optima2-DFC Fresh Air Return Box Dimension Drawing

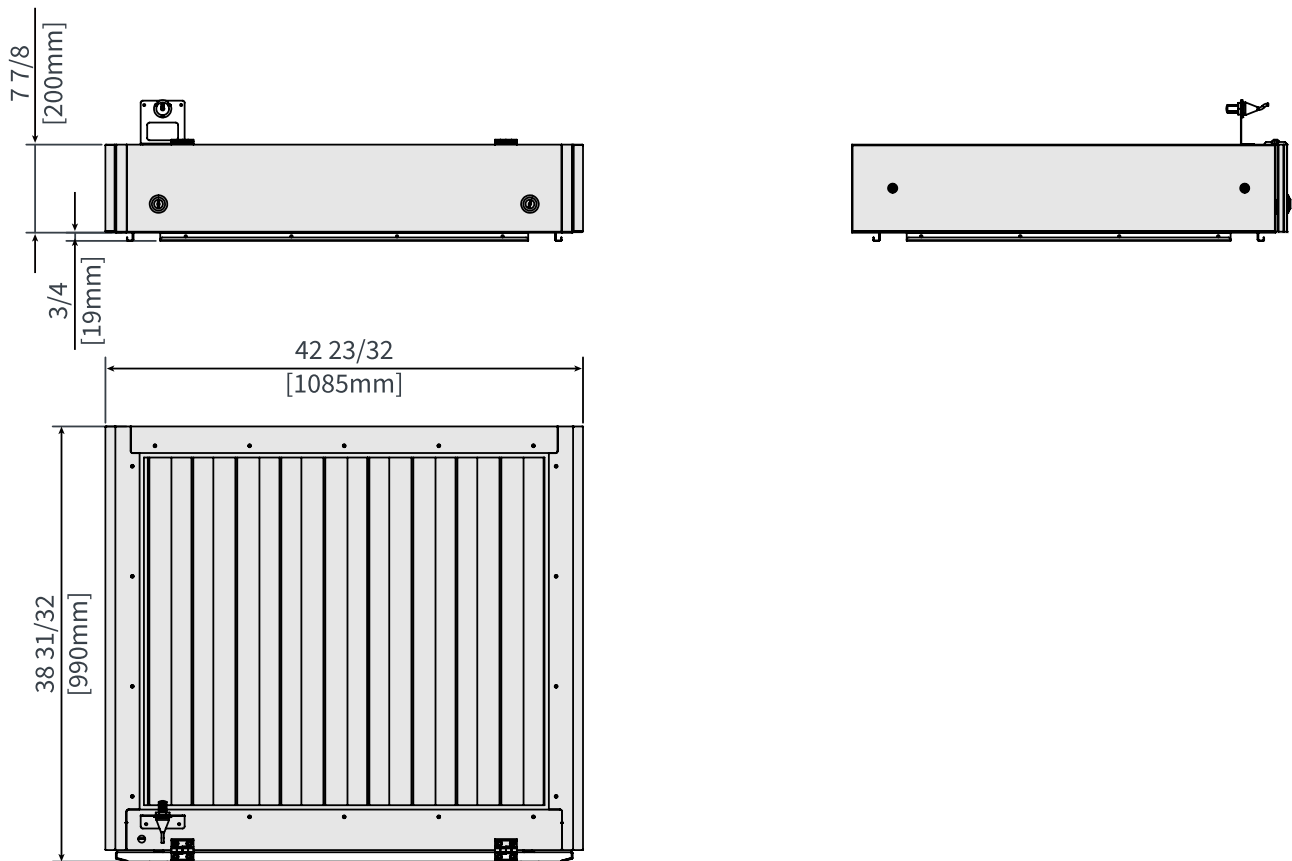

Optima2-DFC Motorized Exhaust Damper & Fan Section

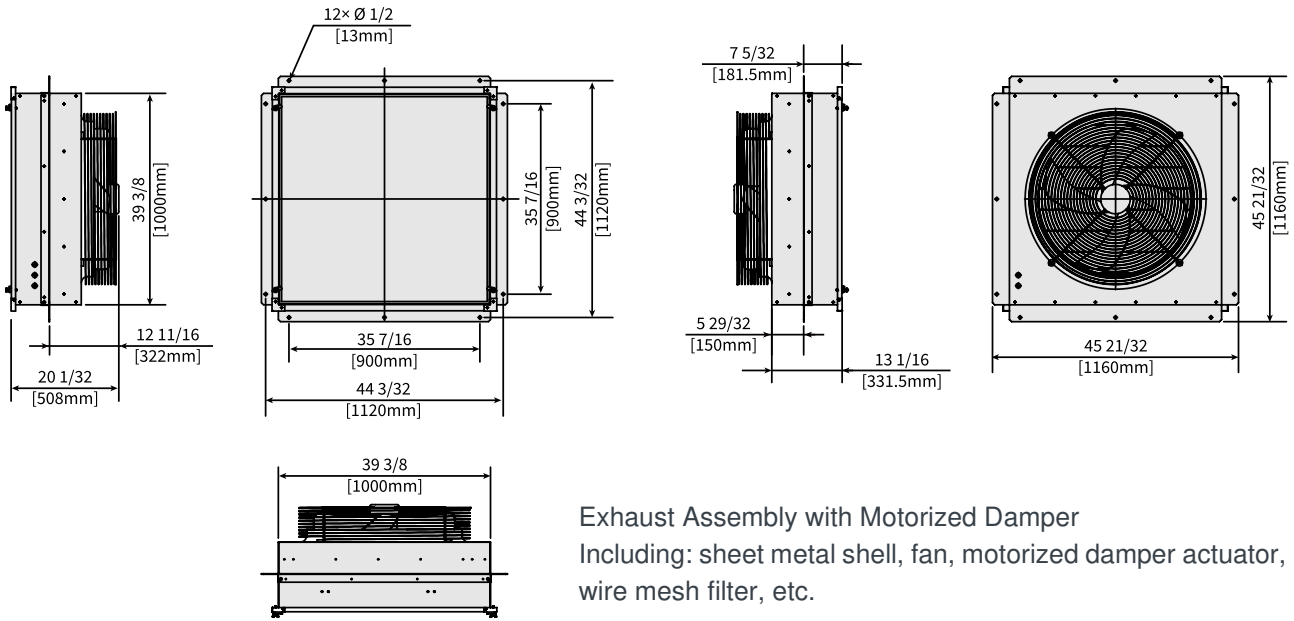

Exhaust Assembly with Motorized Damper
Including: sheet metal shell, fan, motorized damper actuator, wire mesh filter, etc.

Max power: 0.7 kW Max Current: 3.1 A

Optima2-DFC Gravity Exhaust Damper & Fan Section

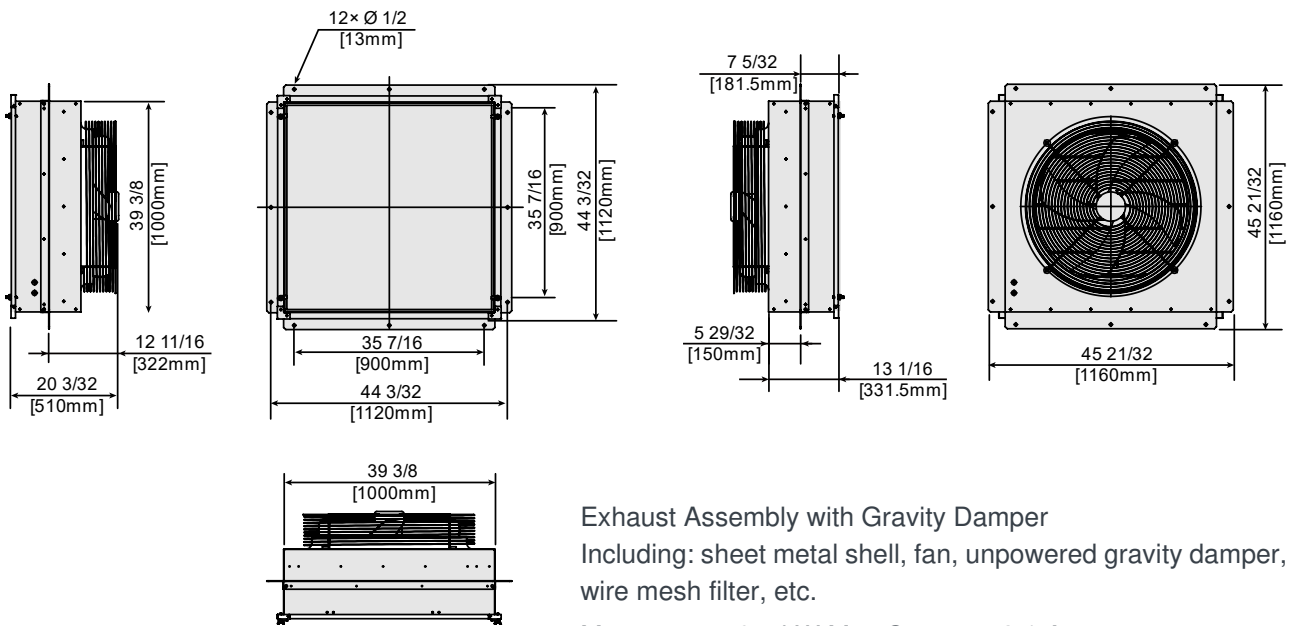

Exhaust Assembly with Gravity Damper
Including: sheet metal shell, fan, unpowered gravity damper, wire mesh filter, etc.

Max power: 0.7 kW Max Current: 3.1 A

Accessory-Adjustable Floor Stand

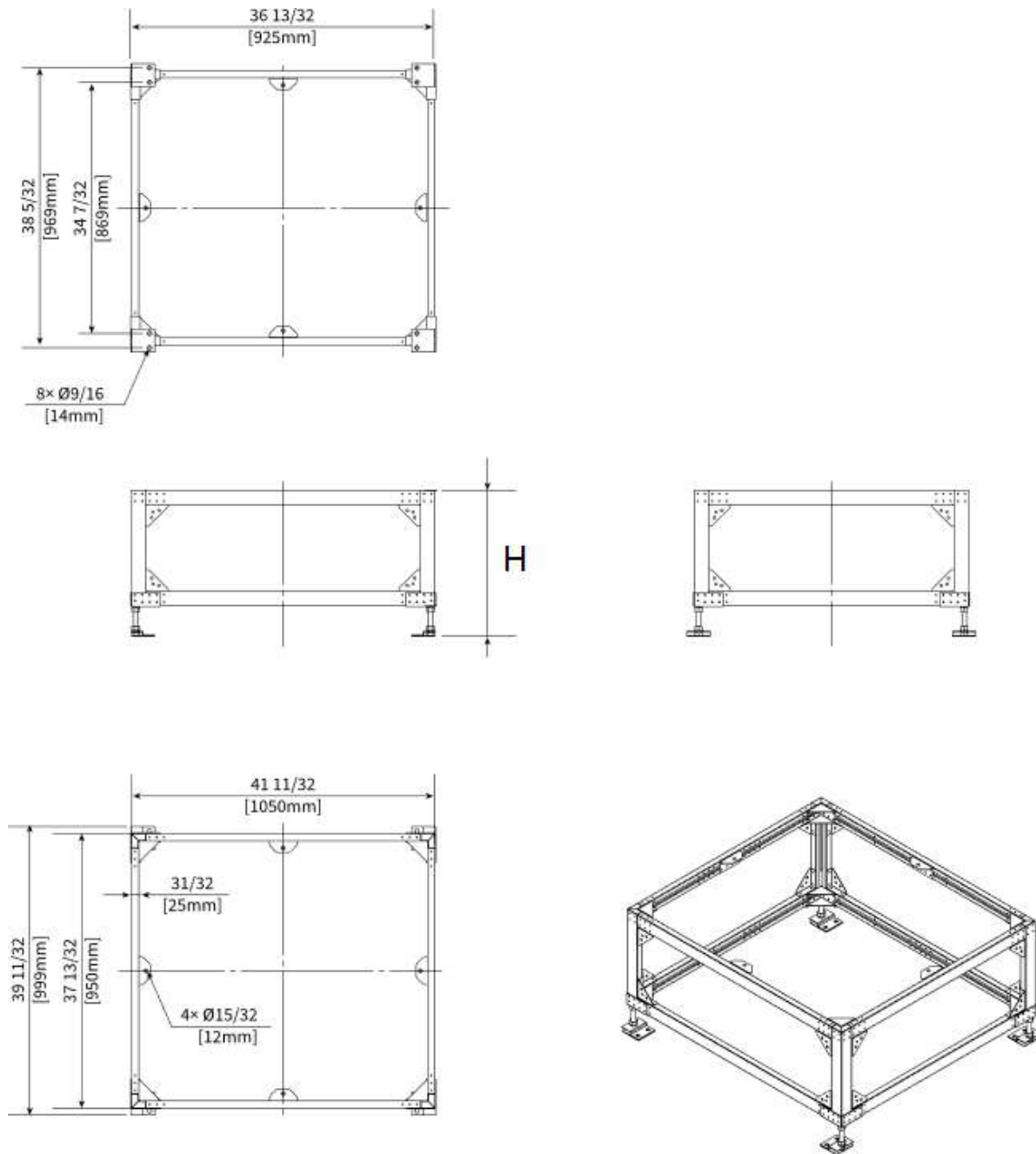

Nominal Height (H)	Adjustable Range (Min)	Adjustable Range (Max)
18in / 457mm	16.5in / 419mm	19.5in / 495mm
21in / 533mm	19.5in / 495mm	22.5in / 572mm
24in / 610mm	22.5in / 572mm	28.5in / 724mm
30in / 762mm	28.5in / 724mm	31.5in / 800mm

Accessory-Supply Air Plenums

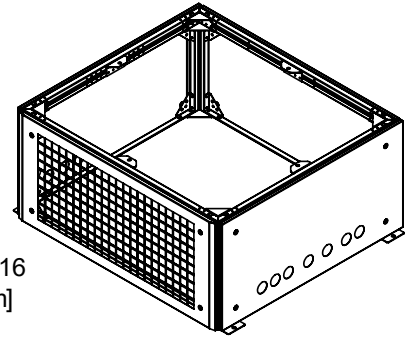
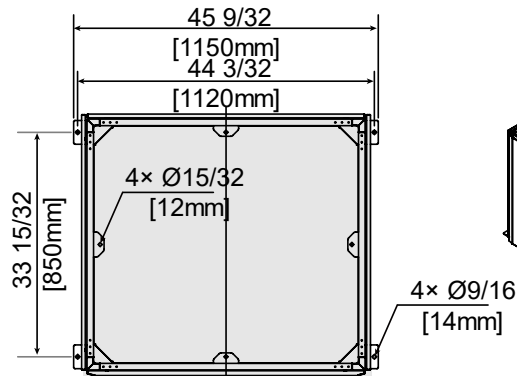
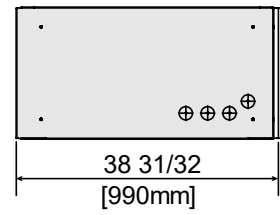
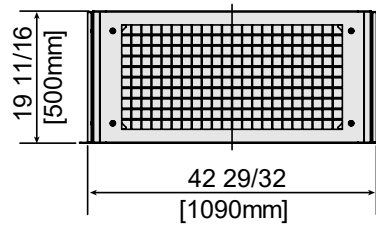

Required Clearance

Optima2- Top Flow & Down Flow

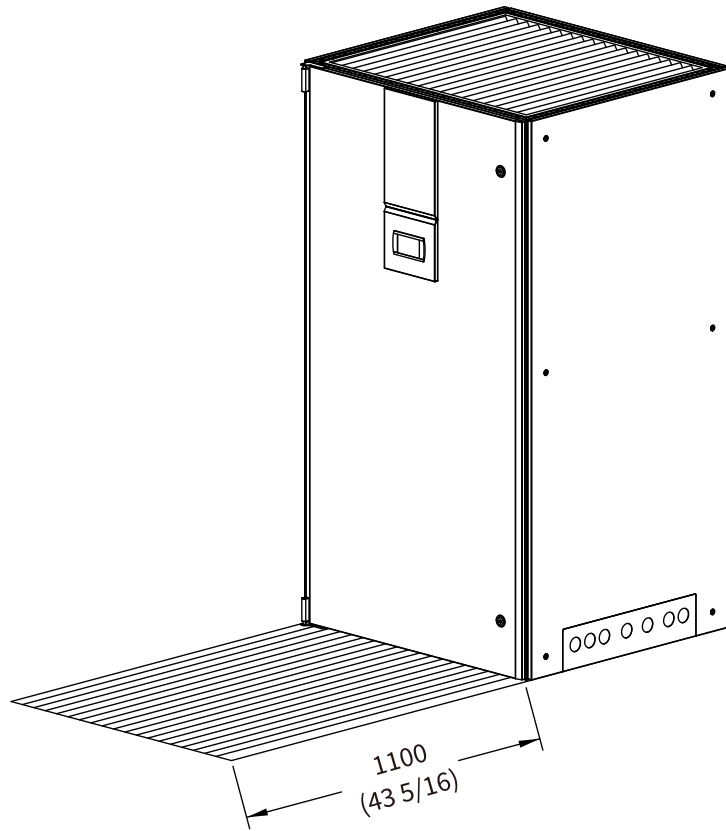



Headquarter

AIRSYS Cooling Technologies, Inc

Add: 7820 Reidville Rd. Greer, SC 29651, USA
Tel: +1 (855) 874 5380
Email: sales@air-sys.us

AIRSYS (UK) Ltd.

Add: 245 Europa Boulevard, Warrington, UK. WA5 7TN
Tel: +44 (0) 1925 377 272
Call Centre: +44(0)8456099950
Email: enquiries@air-sys.uk

AIRSYS Brasil Ltda.

Add: Av. Moaci, 395 Conj 35/36 04083-000 – Planalto
Paulista SAO PAULO – SP
Tel: +55 (11) 25976817 / +55 (11) 21585560
Email: airsys-brasil@air-sys.com.br

AIRSYS Deutschland GmbH

Add: Feringastr. 6, 85774 Unterföhring / München,
Germany
Tel: +49 89 9921 6510
Email: anfragen@air-sys.eu

AIRSYS Refrigeration Engineering Technology (Beijing) Co., Ltd.

Add: 10th floor, Hongkun Shengtong building, 19, Ping
Guo Yuan Xi Xiao Jie, Shijingshan, Beijing, China 100043
Tel: +86(0)10 68656161
Email: airsys@air-sys.com

Gu'an AIRSYS Environment Technology Company Ltd.

Add: 25, Dongfang Street, Gu'an Industry Park, Langfang
City, Hebei Province, China
Tel: +86(0)10 68656161

Shanghai AIRSERVE HVAC System Service Co., Ltd.

Add: Room 1701, Xinda building, No. 322 Xianxia Road,
Changning District, Shanghai, China 200336
Tel: +86(0)21 62452626 Fax: +86 (0)21 6245962

AIRSYS Singapore Pte. Ltd

Add: 50, Tagore Lane Entrepreneur Centre, #03-04 (F),
Singapore 787494
Tel: +65 64991850
Fax: +65 68416301
Email: sales@air-sys.sg

AIRSYS Philippines Corporation

Add: Unit 1603 16th Floor 139 Corporate Centre Building
Valero St. Salcedo Village Bel-Air 1209 Makati,
Philippines.
Tel: +63 84581047
Fax: +63 88470496
Email: sales@air-sys.sg

AIRSYS Malaysia Sdn. Bhd.

NO. 7-1, Jalan 109F, Plaza Danau 2, Taman Danau Desa,
58100 Kuala Lumpur Wilayah Persekutuan Malaysia
Tel: +60 3 7982 2010
Fax: +60 3 7980 1242
Email: sales@air-sys.sg

AIRSYS Australia Sales Office

Add: PO BOX 1088, Flagstaff Hill, SA, 5159, Australia
Tel: +61 479151080
Email: sales@air-sys.sg

Product design and specification are subject to
change without prior notice