

AIRSYS Wall Packaged Units

Troubleshooting Guide



TABLE OF CONTENTS

Safety Instruction	1
1 Model Identification	2
2 Controller Software Identification	2
3 Controller Menus	3
3.1 Menu Structure	3
3.2 Sub Menus	4
4 Alarms Troubleshooting.....	5
4.1 Low Pressure Alarm (A02/A04)	5
4.2 High Pressure Alarm (A03/A06).....	7
4.3 Smoke/Fire Alarm (A05)	9
4.4 High Temp Alarm (A07)	10
4.5 Low Temp Alarm (A08).....	12
4.6 DC Failover (A09).....	14
4.7 Evaporator Fan Overload/AC Loss (A10/A11)	15
4.8 Dirty Air Filter (A15/A16).....	17
4.9 pLAN alarm (A17)	18
4.10 Clock Card Alarm (A18).....	19
4.11 Humidity Sensor Alarm (A19)	19
4.12 Temp Sensor Alarm (A20/A21/A22/A26/A27)	20
4.13 Two Compressor Run (A23)	20
4.14 Damper Alarm (A24/A25)	21
4.15 Generator Run (A28).....	23
4.16 DC Fan Air Flow Alarm (A29/A30).....	24
4.17 AC Loss for DC Fan Systems (A31/A32).....	25
5 Symptoms with No Alarms.....	27
5.1 System function.....	27
5.2 No Controller Display	27

SAFETY INSTRUCTION

IMPORTANT

All service work must be done by qualified professional technicians. Always wear protective gear and comply with all general and local safety standards and codes. Adhere to all warnings and safety instructions on the units and in this manual. AIRSYS and its U.S. distributor, Tempest Telecom Solutions, shall not be held liable for any damage to persons or property due to improper operation or servicing of this equipment.

WARNING

Risk of electric shock. Switch off all electric breakers before servicing the units. Failure to comply can cause serious injury or death.

The Airsys Lead/Lag Controller utilizes 208/230V power and is not electrically isolated from the outdoor units. Some internal sensors and protection devices require and receive voltage from the controller. To ensure that there is no power in the unit, switch off both the controller breaker and the outdoor unit breaker.

WARNING

Risk of contact with high speed rotating fan blades. Turn off the unit and verify that the fan blades have stopped rotating before working around the fans. Failure to comply can cause serious injury or death.

CAUTION

The surfaces of compressors, motors, and discharge lines may become extremely hot during operation. Allow enough time for the components to cool before working on these components. Wear protective gear and exercise caution when working near hot surfaces. Failure to comply can cause injury.

CAUTION

Risk of contact with sharp edges. Always wear protective gloves when handling panels and other components. Failure to comply can cause injury.

1 MODEL IDENTIFICATION

1	2	3	4	5	6	7	8	9
M-OD	13	E1	C3	D	R410	230/1/60	AC	XX

-
- 1 Product Series: Mobilecool-Outdoor Wall Packaged Units
 - 2 Nominal Total Capacity by kW
 - 3 Compressor Type & Qty. E = Scroll, R = Rotary
 - 4 Cabinet size: C1, C2, C3 or C4.
 - 5 Dual or Single unit configuration. Dual if unspecified.
 - 6 Refrigerant. R407c if unspecified.
 - 7 Power source: Voltage/Phase/Frequency. 208-230/1/60 if unspecified.
 - 8 Fan Type: AC or DC EC Fan. AC EC Fan if unspecified.
 - 9 Custom Configuration.

2 CONTROLLER SOFTWARE IDENTIFICATION

The Software Revision Number is in the format of 13BXX. Follow these steps on the Programmable LED display to obtain current software revision.

1. Press **UP** and **DOWN** buttons together to reach **INDOOR TEMP**.
2. press **UP** to reach **5 E 1** and press **SEL** button, the screen should display **5 E P**
3. Press **Down** until the screen displays **1 E 2** then press **SEL**. The number displayed is the current software version, i.e. if 40 is on the screen, the software revision is 13B40.
4. Press **SEL** to return to **1 E 2**, then press **UP** and **DOWN** together to return to **INDOOR TEMP**.

When using the pGD, software revision can be viewed under Maintenance Menu – A1

3 CONTROLLER MENUS

Certain fixes will require navigation through the controller to correct the appropriate settings. Use the Menu Structure below as a guide to access the Main Menu and the various Sub Menu. For a;; two key combinations, place a thumb between the two buttons and press the two keys at the exact same time. You may always return to the main menu by pressing Up and Down at the same time.

3.1 Default Menu Structure

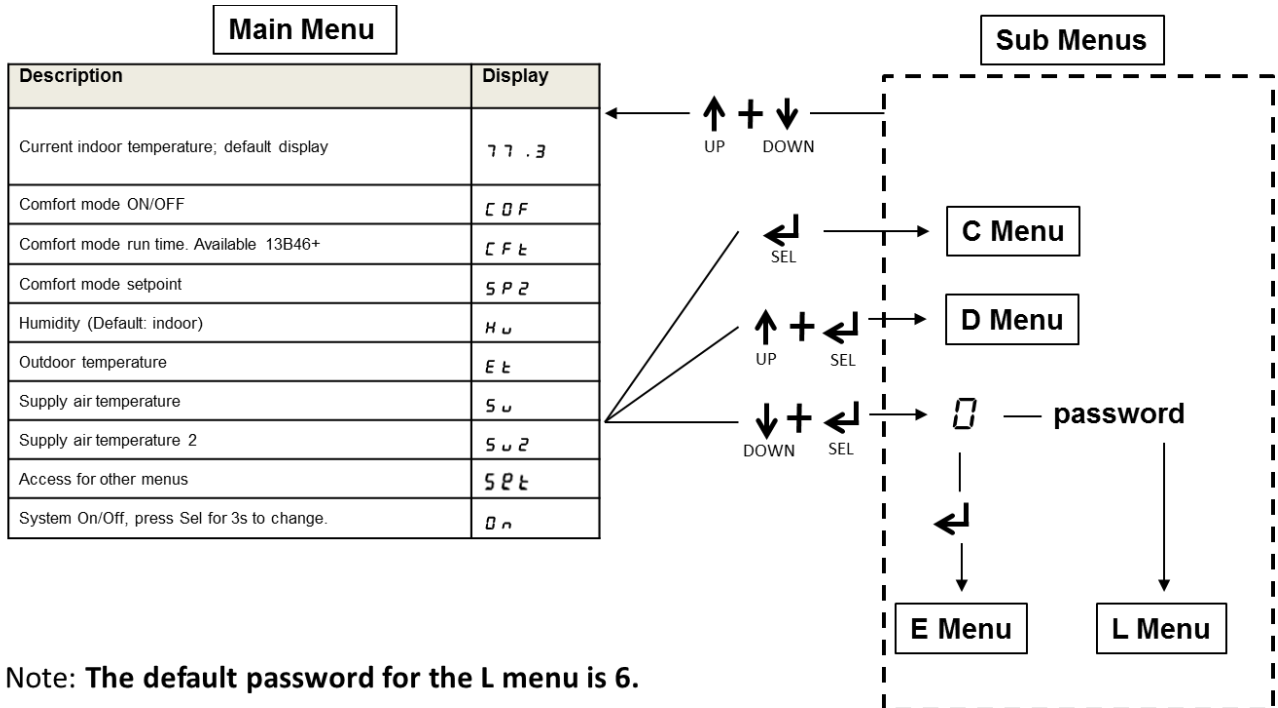

Note: The default password for the L menu is 6.

PGD Menu Structure

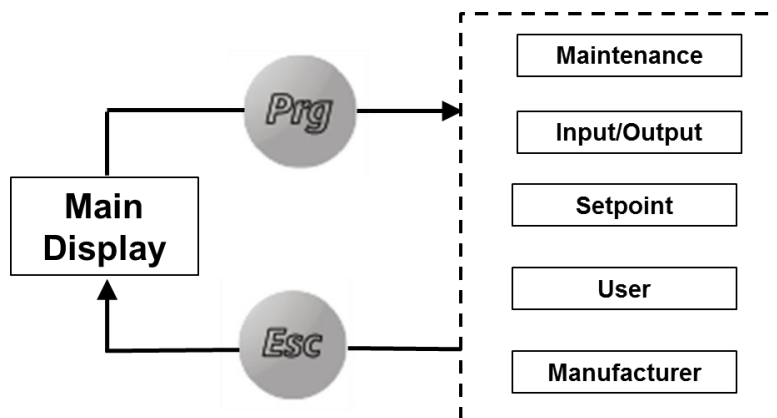

Note: The default password for the pGD is 3

3.2 Sub Menus

A quick reference of the major functions and settings available in each of the sub menu is listed below. Consult the WPU Installation and Operation Manual, available at <http://tempesthvac.com/>, for a complete list of parameters.

Submenu	Functions/Settings Available
C Menu	<ul style="list-style-type: none"> • Temperature Setpoint • Component Running Status • Software Revision • System Time • Sensor Calibration • Manual Mode (System must be OFF) • Alarm History
D Menu	<ul style="list-style-type: none"> • Test Mode • Input/Output Logic (Normally Open vs. Normally Closed) • Supply fan setting (AC vs. DC) • Generator run behavior setting
E Menu	<ul style="list-style-type: none"> • High/Low Temp Alarm Setpoint • Lead Unit Operating Parameters • Controller and Controller Address Settings • Damper Actuator Alarm Settings • Reset Factory Default
L Menu	L01 – Component Running Status L02 – Component Start Count and Running Hours L03 – Current Controller Input/Output L04 – User Settings <ul style="list-style-type: none"> • Conditions for Free Cooling • Minimum Supply air Temperature • Remote Communicate Settings L05 – Manufacturer Settings <ul style="list-style-type: none"> • Turn on/off permanent circulation • Free Cool only during emergency (13B46 and up) • Turn off Free Cooling due to Dirty Filter Alarm • Lag Unit Operating Parameters

3.2.1 PGD Sub Menus

Submenu	Functions/Settings Available
Maintenance	<ul style="list-style-type: none"> • Review software and boot versions • View component Run Time and Start Count • Modify system time • Review Alarm History • Manual Operation mode • Calibrate sensor probes
Input/Out	<ul style="list-style-type: none"> • View current input/output status on the controller:
Setpoint	<ul style="list-style-type: none"> • Change primary temperature setpoint
User	<ul style="list-style-type: none"> • Adjust cooling stages • Heater settings • Humidity control • Free Cooling settings • High/Low Temp alarm setpoints • Step Test (only when system is off) • Comfort Mode
Manufacturer	<ul style="list-style-type: none"> • Communication settings • Alarm inputs (Normally Open vs. Normally Closed) • Supply fan setting (AC vs. DC) • Erase Alarm History • Reset factory defaults

4 ALARMS TROUBLESHOOTING

4.1 Low Pressure Alarm (A02/A04)

A low pressure alarm indicates the controller has received an open signal from the normally closed low pressure switch circuit. Three active alarms within one hour will trigger compressor lockout to protect the refrigerant circuit. Lockout can be cleared by powered cycling the controller. The low pressure alarm is bypassed for the first 60s of compressor startup (adjustable through F1P in L05 Menu or Manufacturer Menu- cg).

4.1.1 Troubleshooting

Possible Cause	Component to Check	Recommended Action
Loose/incorrect alarm wiring	See Low Pressure Alarm Wiring below	If the low pressure switch is closed but the controller is receiving an open signal between ID3 and IDC1, verify/tighten alarm wiring according to diagram below
Compressor start at extreme low temperature	Low pressure bypass	Low pressure bypass can be increased from default 60 seconds to 120seconds through F1P in L05 Menu or Manufacturer Menu - cg
Lack of refrigerant	Low side pressure. Normal Ranges: R407C = 58-102 PSI R410A = 115-175 PSI	<ol style="list-style-type: none"> 1. Restart controller to clear lockout 2. Leak check unit 3. Repair leak if any 4. Charge appropriate amount of refrigerant
Low pressure switch defective	Low pressure switch	If switch is open when low side pressure is in normal range, replace the switch
Reduced airflow	Supply fan Air Filter	Verify supply fan runs properly and air filter is clean. If the fan does not run correctly, refer to section A10/11

4.1.2 Low Pressure Alarm Circuit

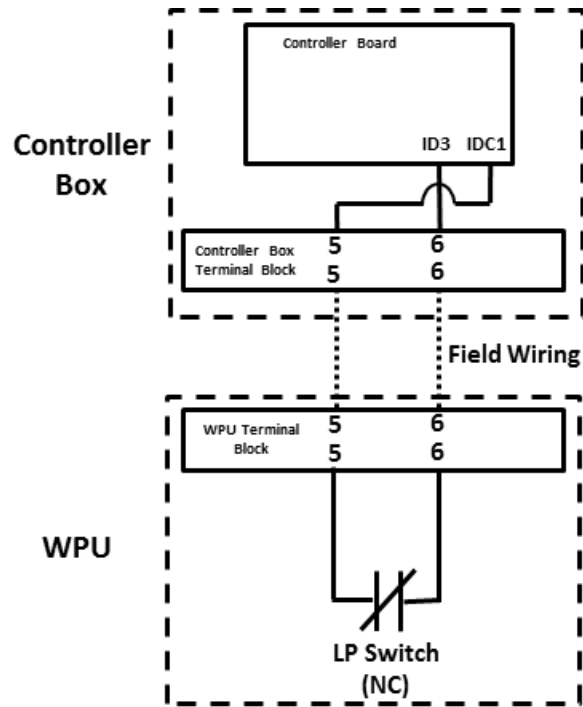

4.2 High Pressure Alarm (A03/A06)

A high pressure alarm indicates the controller has received an open signal from the normally closed high pressure switch circuit. 3 active alarms within one hour will trigger compressor lockout to protect the refrigerant circuit. Lockout can be cleared by powered cycling the controller.

4.2.1 Troubleshooting

Possible Cause	Component to Check	Recommended Action
Condenser coil blockage	Condenser coil	Wash/Clean condenser coil. Remove any blockage.
Loose/incorrect alarm wiring	High Pressure Alarm Wiring (see diagram below)	If the high pressure switch is closed but the controller is receiving an open signal between ID4 and IDC1, verify/tighten alarm wiring according High Pressure Alarm below
Condenser fan wiring	Condenser fan wiring (see diagram below)	If condenser fan does not receive power across wire 120 and wire 400, verify/tighten condenser fan wiring according to Condenser Fan Wiring below
Faulty condenser fan switch	High pressure switch for condenser fan (HP1)	If high pressure switch for condenser fan does not close properly, replace the switch.
Condenser fan relay	condenser fan cycle relay (KA2 for 2.5/3.5 Ton model, KA1 for 5 Ton model)	If the fan cycling relay does not close when the coil is energized, replace the relay.
High Pressure Alarm Switch defective	High pressure alarm switch (HP) HP Switch opens at: R407C: 390/420PSI R410A: 600PSI	If switch is open when high side pressure is in normal range, replace the switch
Condenser fan failure	Power at Condenser fan (240V across wire 120 and wire 400)	If condenser fan receives power but does not run, replace the condenser fan.

4.2.2 Condenser Fan Wiring

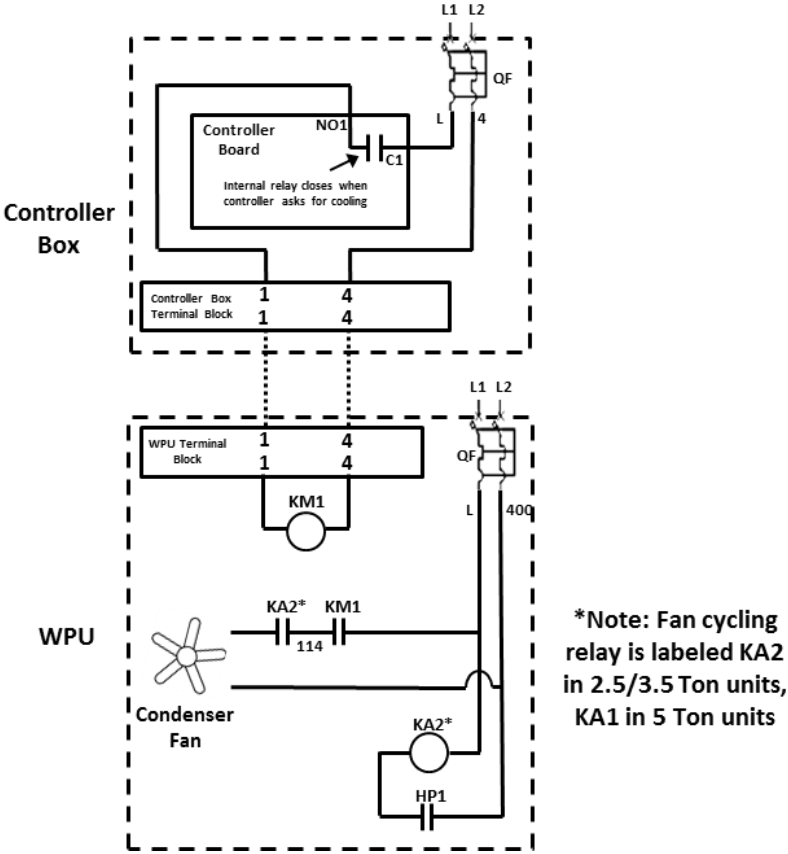

4.2.3 High Pressure Alarm Wiring

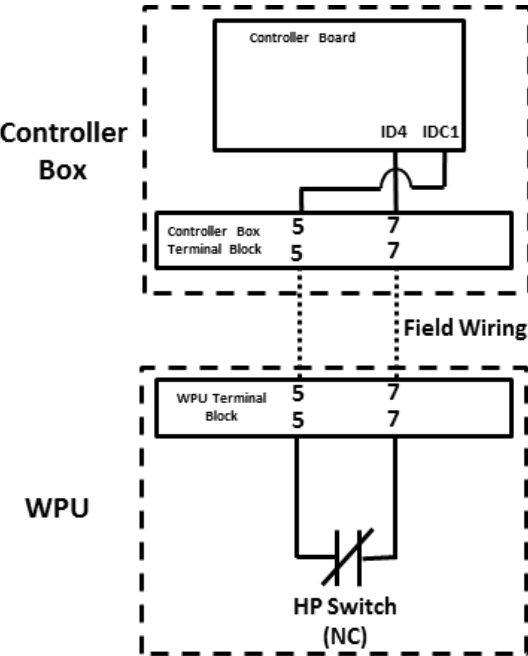

4.3 Smoke/Fire Alarm (A05)

The controller receives a normally closed signal (can be changed to normally open at $S F \xi$ under D Menu or Manufacturer Menu – C2a) from the smoke/fire detector on terminal 41 and 5. When the controller receives an active smoke/fire alarm, all components on both units will shut to minimize airflow within the site: outside air damper, heater, compressor, and supply fan. This alarm is reset automatically when alarm is no longer active.

Note: The normally open or normally closed signal **must be isolated relay contacts**. Piggybacking with other devices may cause false alarm.

4.3.1 Troubleshooting

Possible Cause	Component to Check	Recommended Action
Incorrect input signal setting	$S F \xi$ parameter in D Menu and input signal on terminal 41 and 5	Adjust $S F \xi$ in D Menu to switch between normally open and normally closed alarm input. If using the pGD, this parameter can be accessed under Manufacturer Menu – C2a
Loose/incorrect alarm wire	Smoke/Fire alarm wiring (see diagram below)	If the detector relay is closed but the controller is receiving an open signal between ID4 and IDC1, verify/tighten alarm wiring according Smoke Fire Alarm Wiring below.
Smoke/Fire detector is falsely triggered	Smoke/Fire detector	If defective, replace detector

4.3.2 Smoke Fire Alarm Wiring

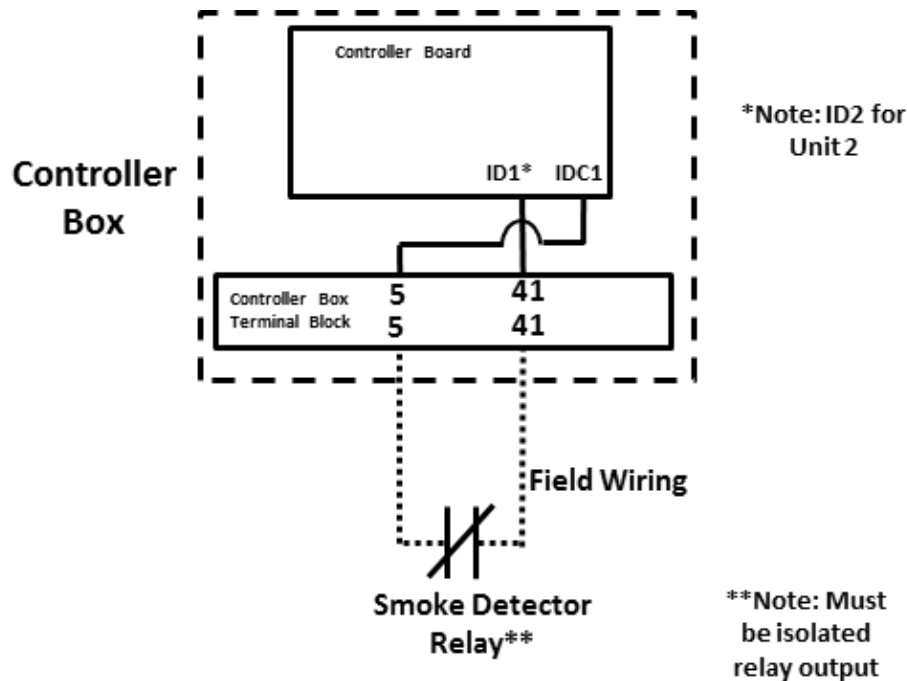

4.4 High Temp Alarm (A07)

High Temp Alarm is triggered when the indoor temperature exceeds temperature setpoint + high temp alarm trigger (default = 18°F). This alarm has a built-in 1 minute delay (can be eliminated at F35 under L05 Menu).

4.4.1 Troubleshooting

Possible Cause	Component to Check	Recommended Action
Reduced cooling capacity	Filter, condenser coil, low side pressure	Clean/wash filter and condenser. Remove blockage if appropriate. Leak check/ repair if low on refrigerant.
Improper value set for high temp alarm trigger	H E under E menu or other thermostat used to monitor high temperature If using the pGD, this parameter can be accessed from User Menu – P8	Default = 18°F.
Undersized unit	Check if the heat load of the site exceeds sensible capacity of the AC units	Add/Upgrade AC or remove unused equipment
Cooling command not given by controller	Check for other alarms present on controller. Use D52/D57 under C Menu to view current compressor command for unit1/unit2 respectively	Correct other alarms that would prevent compressor start up, such as high/low pressure lockout and smoke/fire alarm.
Improper value set for compressor turn on	Lead compressor turn on: E 2 under E menu Lag compressor turn on: F 3 B under L05 Menu If using the pGD, these parameter can be accessed under User Menu.	Correct compressor settings.
Compressor circuit failure	Compressor. Compressor contactor (KM1) Compressor run caps (C) Compressor circuit wiring	Replace failed component. Correct/tighten wiring according to Compressor Circuit diagram below
Indoor temperature sensor	Indoor temp sensor (ST1) Indoor temp sensor calibration (n 2 R under C menu) Backup Indoor temp sensor (ST2) Backup indoor temp sensor calibration (n 4 2 under C Menu) If using the pGD, calibrations can be accessed in Maintenance Menu	Verify sensor operation. Correct calibration.

4.4.2 Compressor Circuit

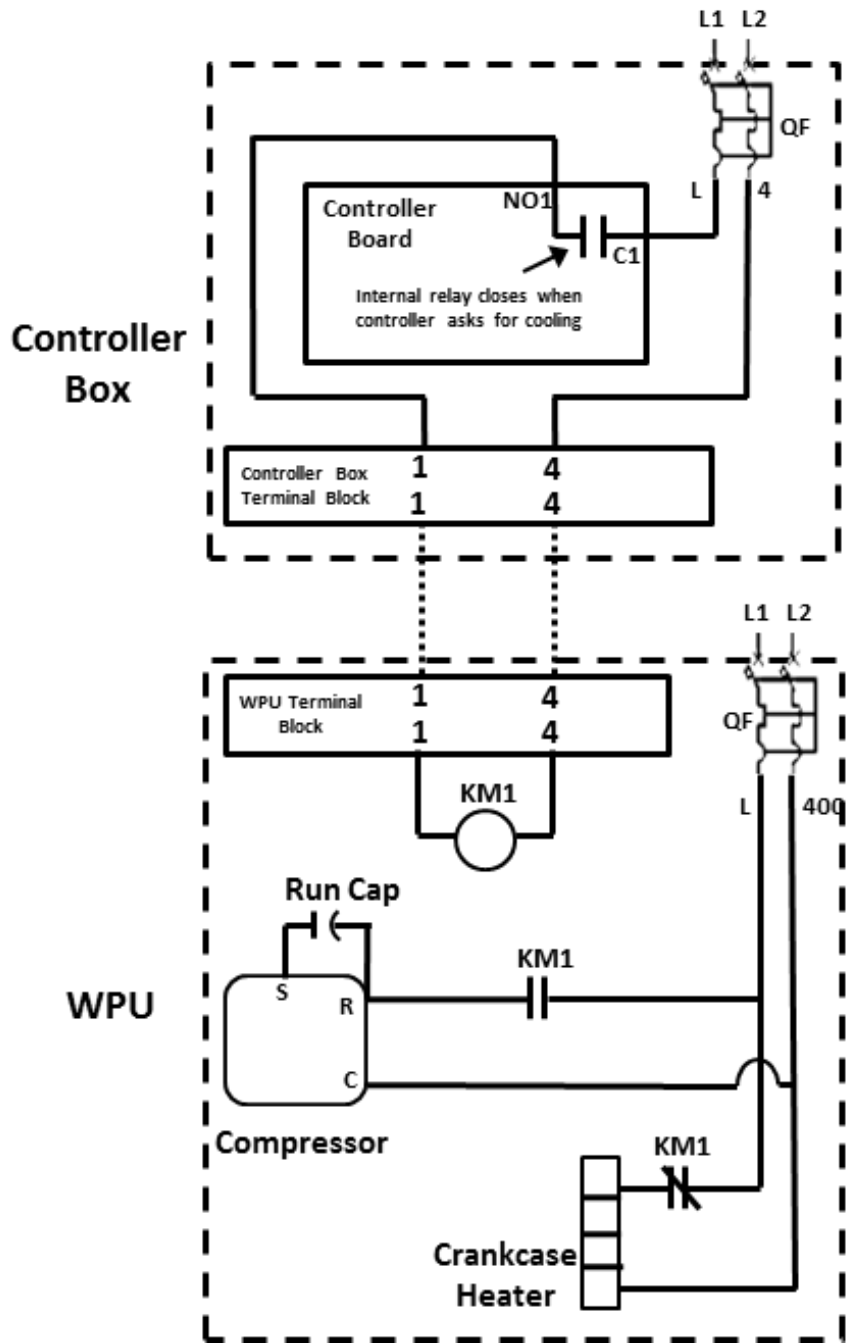

4.5 Low Temp Alarm (A08)

Low Temp Alarm is triggered when the indoor temperature drops below temperature setpoint - low temp alarm trigger (default = 32°F). This alarm has built-in 1 minute delay.

The WPU is designed for equipment sites where they are usually unoccupied. As such, the heater by default turns on 27 degrees below the main setpoint. Comfort mode is recommended if equipment site is temporarily occupied.

4.5.1 Troubleshooting

Possible Cause	Component to Check	Recommended Action
Improper value set for low temp alarm trigger	L E under E menu or other thermostat used to monitor site temperature	Default = 32°F below the main setpoint
Improper value set for heater turn on	Lead compressor turn on: H Q Z under E menu. Lag compressor turn on: F 3 B under L05 Menu If using the pGD, these parameters can be accessed from the User Menu.	Correct heater settings.
Cooling command not given by controller	Other alarms in the system Use D53/D58 under C Menu to view current heater command for unit1/unit2 respectively. If using the pGD, use Input/Output Menu to view current commands.	Correct other alarms that would prevent heater start up, such as fan overload.
Heater circuit failure	Heater Heater contactor (KM2) Heater protection device (fused, located behind supply grill) Heater circuit wiring	Replace failed component. Correct/tighten wiring according to Heater Wiring Diagram below.
Indoor temperature sensor calibration	Indoor temp sensor (ST1) Indoor temp sensor calibration (n Z B under C menu) Backup Indoor temp sensor (ST2) Backup indoor temp sensor calibration (n 4 Z under C Menu)	Verify sensor operation. Correct calibration.

4.5.2 Heater Wiring

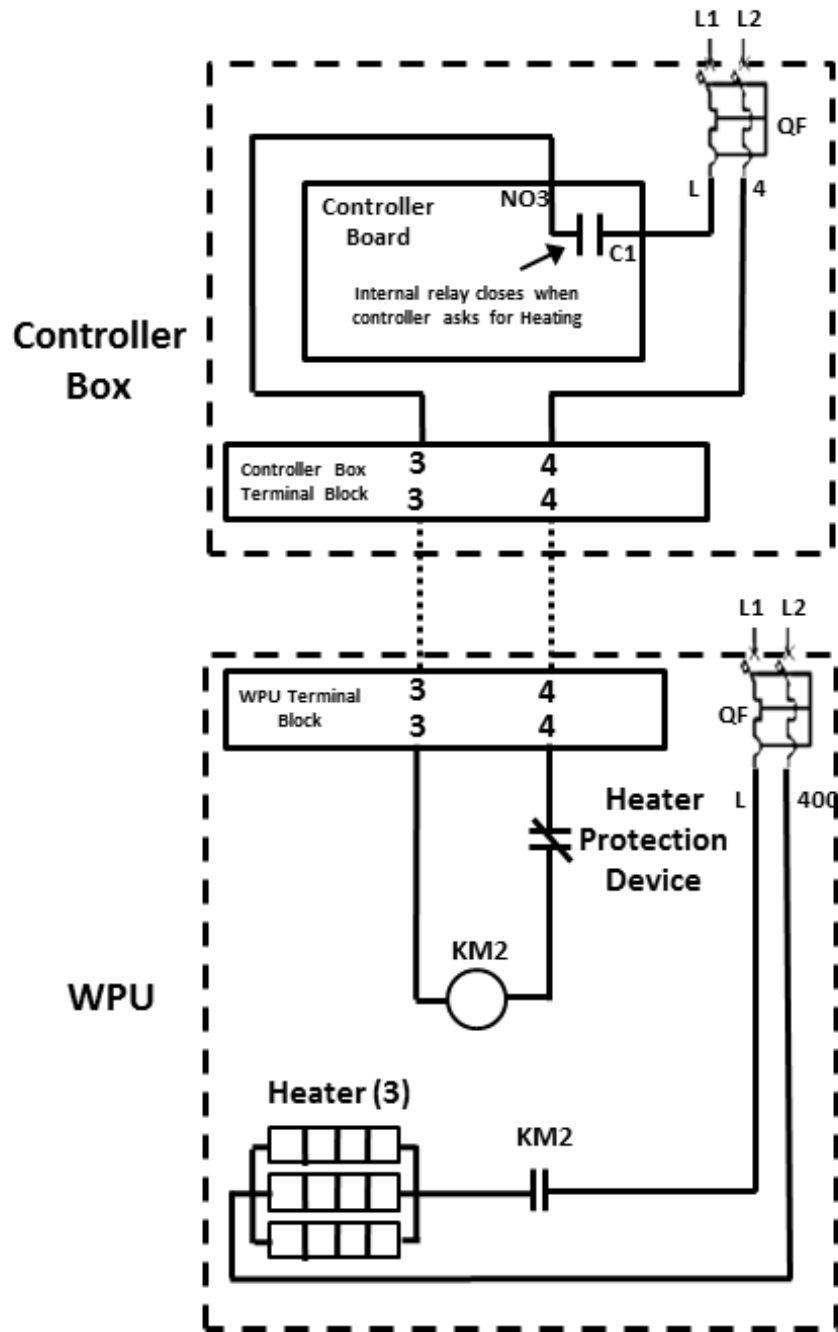

4.6 DC Failover (A09)

A09 is only available when DC Failover Box (ASPCB.24/48) is installed. The controller will not operate compressor or heater when the DC Failover Box is active.

4.6.1 Troubleshooting

Possible Cause	Component to Check	Recommended Action
DC Failover Box Active	Prime power (208/230V) into the DC failover box. Prime power phase: Must have L1, L2 connected in right order on both input breakers (QF1, QF2)	Verify prime power into the DC failover box Phasing: Should have 0V across left side of QF1 and left side of QF2, 240V across left side of QF1 and right side of QF2.
Loose/incorrect wiring	Alarm circuit	If A09 is present when the DC Failover Box is not installed or not active, check wiring according to DC Failover Alarm Circuit below

4.6.2 DC-Failover Alarm Circuit

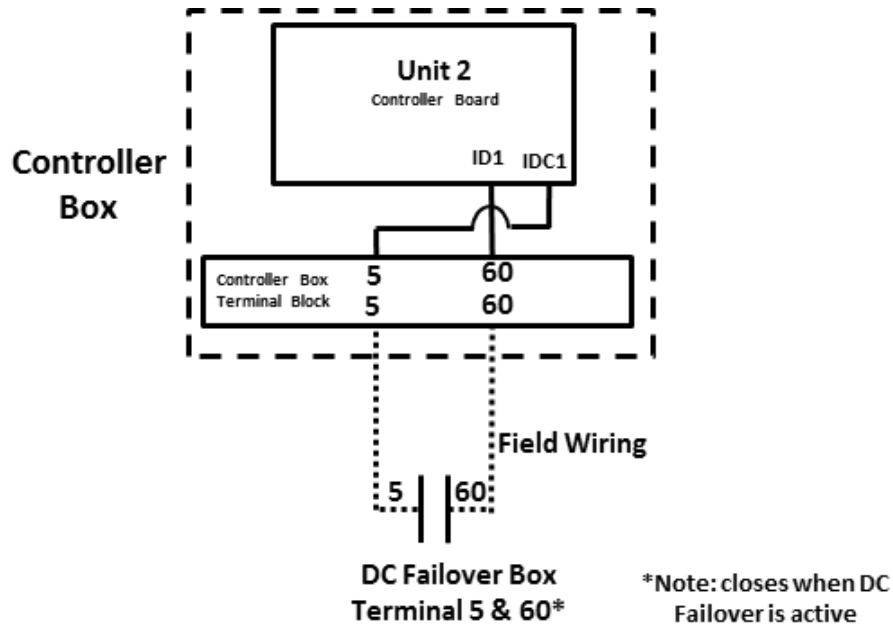

4.7 Evaporator Fan Overload/AC Loss (A10/A11)

The normally closed evaporator overload feedback opens at terminal 5 & 9 when either the supply fan has been physically blocked or that it does not receive the correct power supply (208/230VAC +/- 10%). This alarm also serves as a warning when no power is applied to the WPU.

Note: Evaporator Overload alarm only applies to AC powered supply fans. If this alarm is display when the power supply for the fan is DC, change the fan setting SF1 in D menu from 1 to 0. See Chapter 2 Model Identification to determine supply fan power input.

4.7.1 Troubleshooting

Possible Cause	Component to Check	Recommended Action
No power input to the system	Verify 208/230VAC at the input breaker (QF)	Turn on breaker/power supply. Correct
No power input to the supply fan	Verify 208/230VAC across wire 401/402 for 5 Ton model and 401/400 for other models. Verify Evap. Fan	Correct wiring. Replace fan relay if faulty.
Loose/incorrect feedback wiring	Alarm wiring	Refer to Fan Overload Alarm Wiring Below
Faulty overload switch	Normally closed overload output (two white wires coming from the supply fan)	If 208VAC is verified going into the supply fan and the two white wires connecting to 5 and 9 are still open, replace the fan

4.7.2 Fan Overload Alarm Wiring

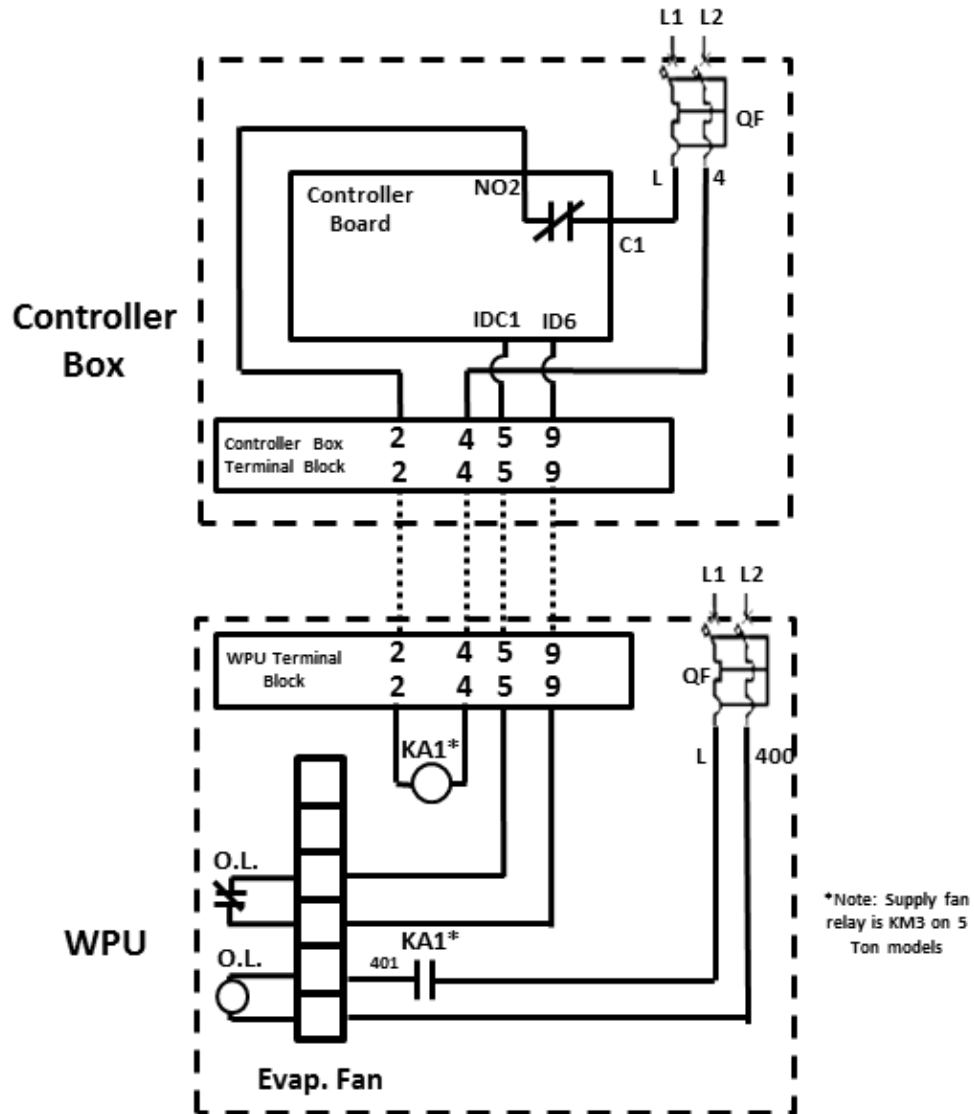

4.8 Dirty Air Filter (A15/A16)

If the air filter is dirty, excess pressure will build up across the filter, triggering the normally closed air pressure switch (PF) to open.

4.8.1 Troubleshooting

Possible Cause	Component to Check	Recommended Action
Dirty Air Filter	Air filter. Open the middle-front panel to access the filters.	Replace air filter
Incorrect wiring	Alarm wiring	Correct wiring. Refer to Dirty Air Filter Alarm Wiring below
Incorrect air pressure switch setting	Arrow on the dial should be pointing at 250	Correct setting to 250
Faulty air pressure switch	Air pressure switch	If the switch is open while the filter is clean and setting is correct, replace the switch

4.8.2 Dirty Air Filter Alarm Wiring

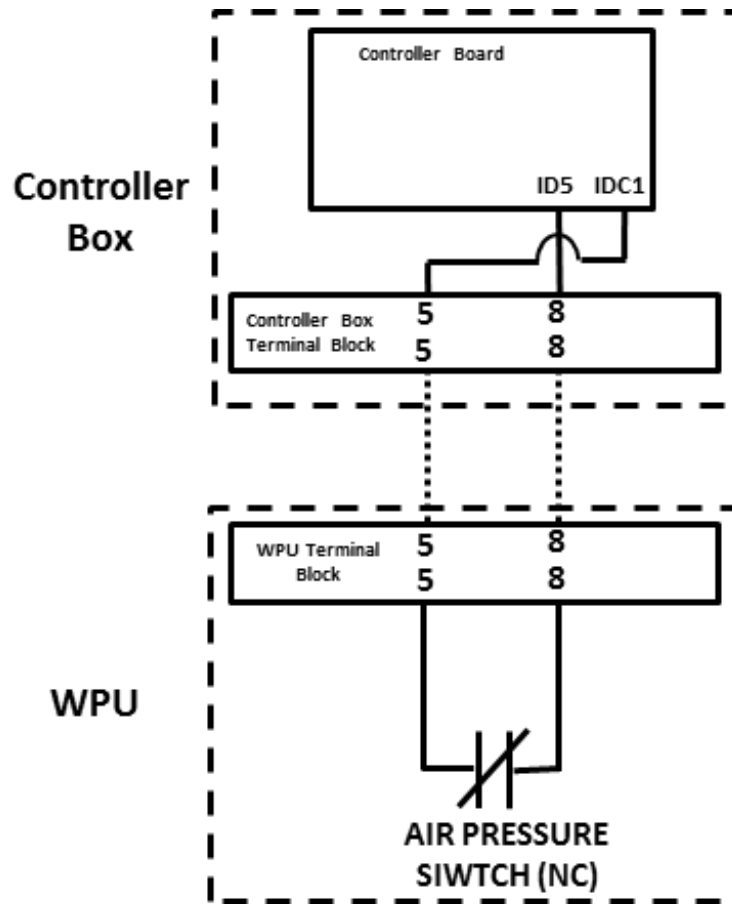

4.9 pLAN alarm (A17)

pLAN is the communication wire between unit 1 and unit 2 controller board. The units will act independently when the communication is lost.

4.9.1 Troubleshooting

Possible Cause	Component to Check	Recommended Action
Loose connector	pLAN connector on J6 block at each controller board	Push in connector
Incorrect Controller Address	CAD under E menu. CAD must be 1 for unit 1 and 2 for unit 2	Correct setting. Move the display connector (J7) to unit 2 to configure unit 2 address
Controller board failure/power loss	24VDC on across J1 Power supply LED light between J8 and J9 should be lit	Secure power input connector. Replace controller board is power is present but controller board does not power on. Refer to Controller board LED status below

4.9.2 Controller board LED status

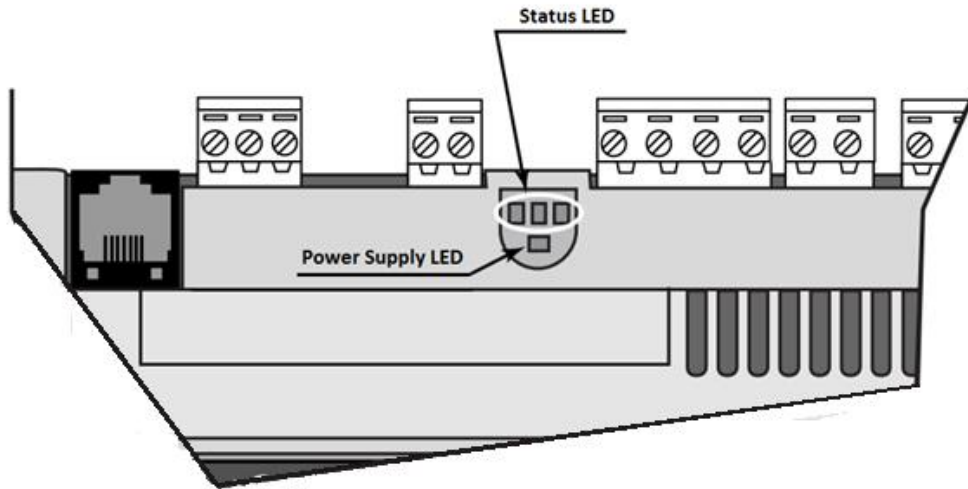

Power Supply LED (Yellow)			Description
●			Indicates power supply to the module
Status LED			Description
Red	Yellow	Green	Description
○	○	○	Cannot identify other unit through pLAN: Loose pLAN connection OR wrong controller address
●	○	○	Software error: No pLAN address set
○	●	●	Module operating correctly with pLAN

4.10 Clock Card Alarm (A18)

Clock Card Alarm occurs when the clock card is loose or its battery has drained. Clock card is able to track system time even when the system is not powered for up to 8 months at a time. The battery is recharged when the system is powered again. The clockcard is located below the J6 pLAN block on the top left of the controller board.

4.10.1 Troubleshooting

Possible Cause	Component to Check	Recommended Action
Loose clockcard	Clock card	Push in connector
Defective clockcard/battery	Clock card	Replace Clock Card

4.11 Humidity Sensor Alarm (A19)

In software version 13B40 and below humidity Sensor alarm occurs when the humidity exceeds 90% or when the sensor is disconnected. Humidity alarm only occurs if the sensor is disconnected in software versions after 13B40.

4.11.1 Troubleshooting

Possible Cause	Component to Check	Recommended Action
Low heat load, site cools down without compressor	Free cooling humidity limit (U04 in L04 Menu)	Change to 80%. For extremely small heat load site, change to 60%.
Loose/incorrect sensor wire	Sensor wire	Correct wiring. Refer to Humidity Sensor Wiring below
Defective humidity sensor	Humidity sensor	Replace Humidity Sensor

4.11.2 Humidity Sensor Wiring

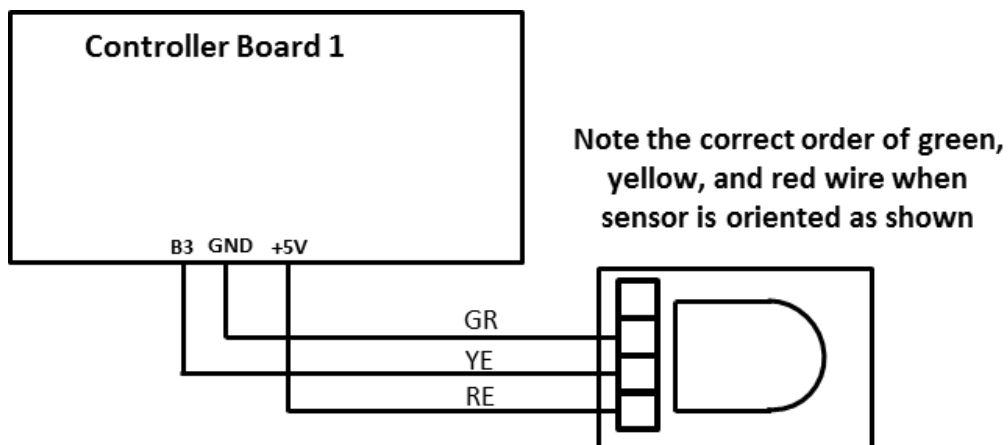

4.12 Temp Sensor Alarm (A20/A21/A22/A26/A27)

Temperature sensor alarms occur when the sensor is defective or disconnected. Temp sensors are not orientation sensitive and can be connected in both ways.

4.12.1 Troubleshooting

Possible Cause	Component to Check	Recommended Action
Temperature sensor disconnected/loose	Wire connection	Refer to Temp Sensor Wiring below.
Temperature sensor Defective or wire broken	Sensor and wiring. Use the main menu to check current sensor readings	Replace irresponsible sensor after wiring is verified

4.12.2 Temp Sensor Wiring

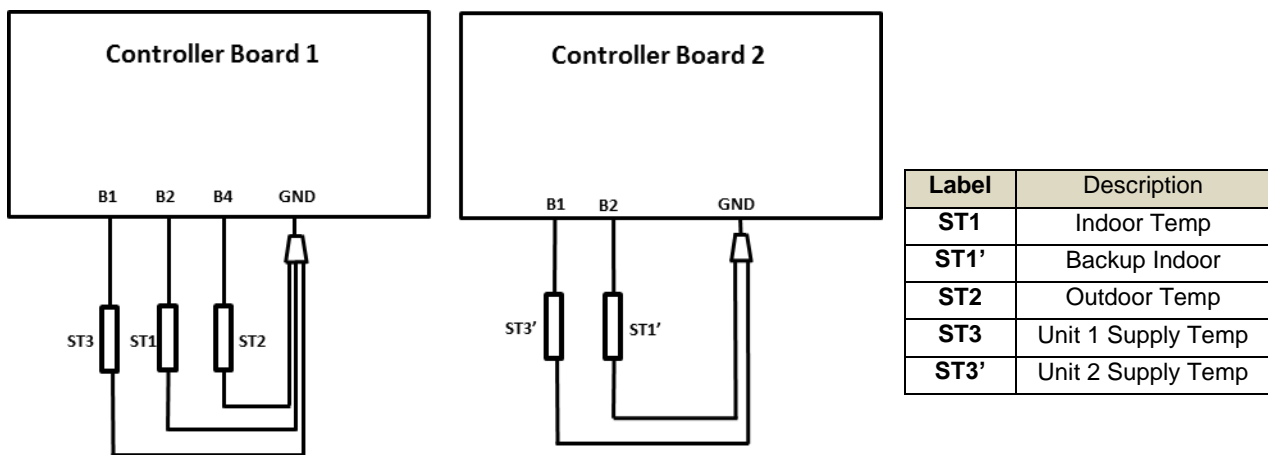

4.13 Two Compressor Run (A23)

Two Compressor Run alarm occurs whenever the two units are required to use mechanical cooling at the same time. This alarm is an early warning that one of the unit may have reduced its cooling capacity.

4.13.1 Troubleshooting

Possible Cause	Component to Check	Recommended Action
Reduced capacity on one unit	Air filter, condenser, refrigerant charge	Replace filter, clean condenser, and recharge refrigerant.
One unit unable to use mechanical cooling due to other alarms	Check whether mechanical cooling is locked out due to	Correct other alarms first
Shelter heat load exceed one unit's sensible capacity	Shelter heat load, unit sensible capacity	Add/upgrade unit. Remove unused equipment.
Exceptional high outdoor temperature	Air leaks, passive ventilation	Minimize air exchange during hot weather reduces total heat load
Improper lag unit turn on point	F38 under L05 Menu	Recommended at least 5F for F38

4.14 Damper Alarm (A24/A25)

The controller verified proper damper positioning by comparing the supply air temperature with outdoor/indoor temperature. If the damper should be completely open, the supply temperature should be the same as the outdoor temperature within a tolerance (configurable at FC2 under E Menu). If the damper should be completely closed, the supply temperature should be the same as indoor temperature within in tolerance (configurable at FC3 under E menu).

4.14.1 Troubleshooting

Since the controller checks the damper by comparing temperatures, improper setup of the temperature sensors can cause erroneous alarm. Verify each damper’s physical movement through the step test. If the damper behaves correctly, refer to **Sensor Setup Correction** below. If the damper does not behave correctly, move to **Damper Fail** section below.

Sensor Setup Correction

Possible Cause	Component to Check	Recommended Action
Incorrect supply air temperature setup	St3 must be in the supply air stream of unit 1. St3’ must be in the supply air stream of unit 2.	Correct temperature setup. Refer to Temp Sensor Wiring on page 20
Insufficient temperature tolerance	FC2/3 under E menu	Increase to 15-20F
Improper outdoor temp sensor placement	Outdoor temp sensor box must be placed in the shade. Indoor air leakage through the wall into the sensor box	Move the outdoor sensor box into shade. Seal the air leakage

Damper Fail

Possible Cause	Component to Check	Recommended Action
Tightening nuts on damper actuator loose	Nuts on damper actuator. Damper actuator can be accessed from the damper inspection panel on the side of the unit.	Tighten down.
Loose/incorrect damper actuator wiring	Damper wiring: 24VDC between 12 and 13 for power, 10VDC between 10 and 12 for open position.	Correct wiring. Refer to Damper Actuator Wiring below
Incorrect damper actuator setting	Check if damper actuator is moving in reverse direction	Correct setting. The black round dial on the face of the damper actuator must be set to 0.

4.14.2 Damper Actuator Wiring

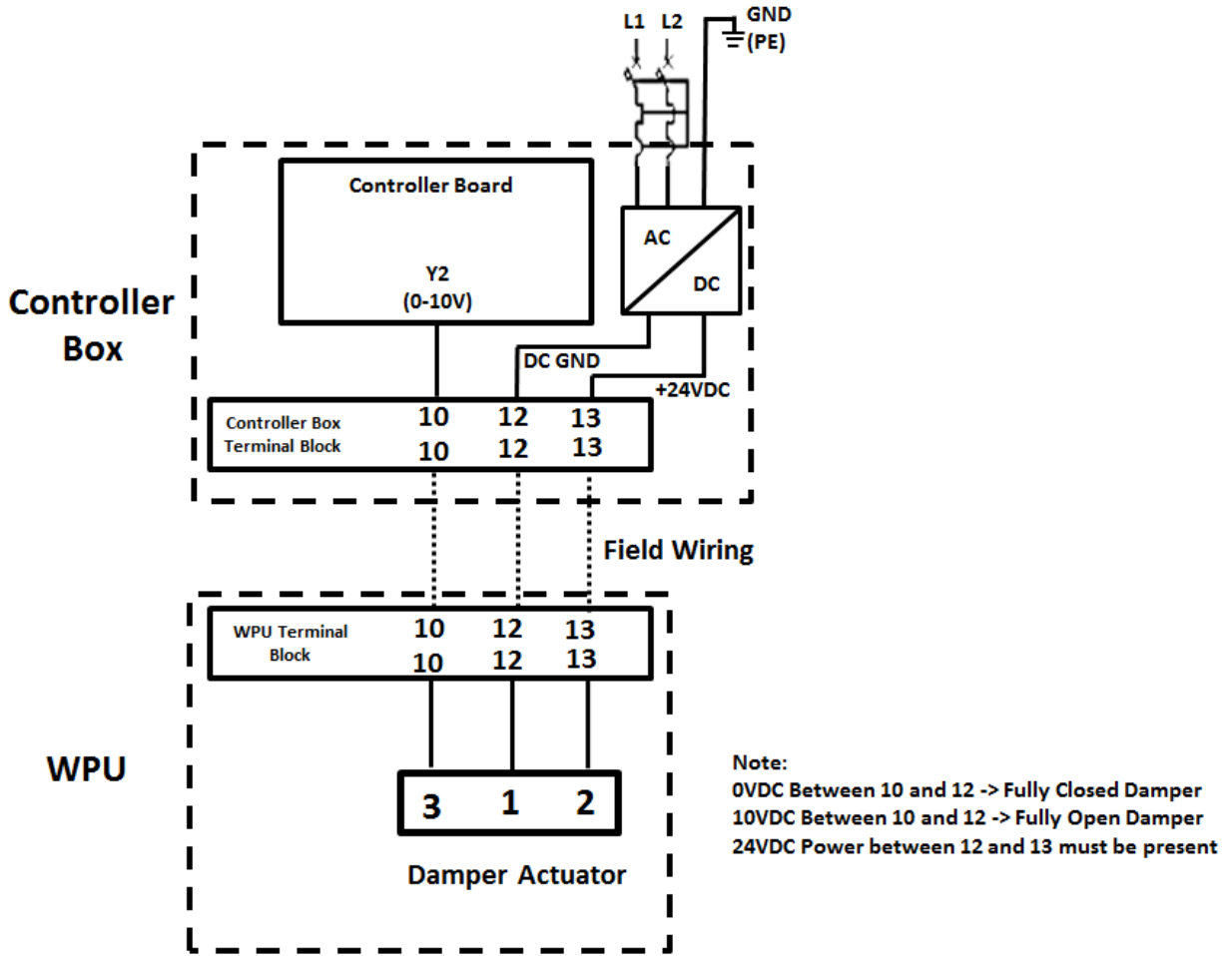

4.15 Generator Run (A28)

The controller receives a normally open signal (can be changed to normally close at DGt under the D Menu) from the generator on terminal 42 and 5. When the controller receives an active generator run signal, free cooling will be shut down and as well as the lag unit. For large generators, the lag unit can be enabled during generator run at E2C under the D Menu. The compressors will also engage a 3minute delay when the generator turns on/off. Delay duration can be configured at CSt under the D Menu

4.15.1 Troubleshooting

Possible Cause	Component to Check	Recommended Action
Generator is running	Generator	n/a
Incorrect input signal setting	d G t parameter in D Menu and input signal on terminal 42 and 5	Adjust d G t in D Menu to switch between normally open and normally closed alarm input
Loose/incorrect alarm wire	Alarm wiring	Verify/tighten alarm wiring according Generator Wiring below.

4.16 DC Fan Air Flow Alarm (A29/A30)

Note: A29/A30 only applies to DC powered supply fans. If this alarm is display when the power supply for the fan is AC, change the fan setting SF1 in D menu from 0 to 1. See Chapter 2 Model Identification to determine supply fan power input.

When the DC fan is running, pressure is built up across the air pressure differential switches (PF2 & PF3) and the terminal 5 & 9 will close. If the pressure switch does not close after 60 seconds, A29/30 will trigger, indicating problems with the supply fan.

4.16.1 Troubleshooting

Possible Cause	Component to Check	Recommended Action
No power to DC fan	Verify 48VDC presence on DC breaker. Verify 48VDC across 12 and 131 to the supply fan	Correct DC power supply
Incorrect DC polarity	Red probe on +48 terminal and black probe on - 48 terminal should give a +48VDC reading. Verify controller side as well	Correct DC polarity
No speed signal to DC fan	Speed signal between 11 and 12.	Verify 0-10 VDC signal between terminal 11 and 12.
Incorrect alarm wiring	Alarm wiring	Verify wiring per DC Fan Air Flow Alarm Wiring below
Faulty air pressure differential switch	Air pressure differential switch should close when the fan is running at high speed	Replace air pressure differential switch

4.16.2 DC Fan Air Flow Alarm Wiring

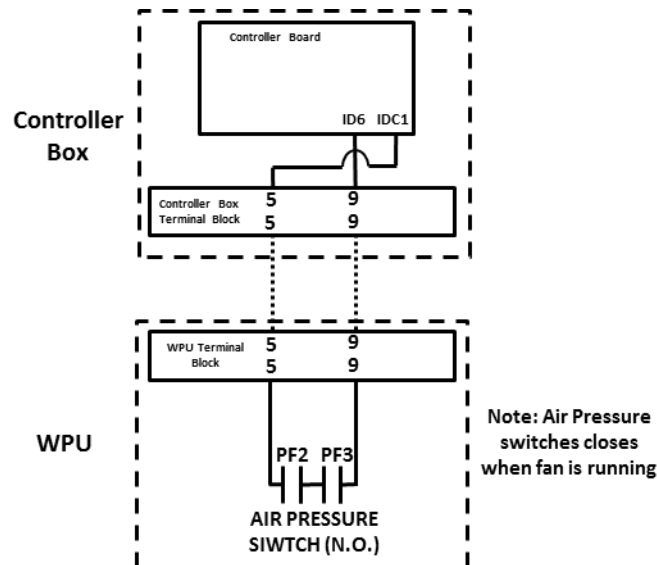

4.17 AC Loss for DC Fan Systems (A31/A32)

Important: A31/A32 only applies to DC powered supply fans. If this alarm is display when the power supply for the fan is AC, change the fan setting SF1 in D menu from 0 to 1. See Chapter 2 Model Identification to determine supply fan power input.

An open signal between terminal 2 and 12 will trigger this alarm.

4.17.1 Single Phase AC Loss Troubleshooting

(See next page for 3 phase AC)

Possible Cause	Component to Check	Recommended Action
AC Loss	AC Breaker on units	Turn on breaker and make sure prime power is present to the unit
Power loss relay failure	Power relay (KA1)	If relay does not close when power in applied to the coil, replace the relay
Loose/incorrect alarm wire	Alarm wiring	Verify/tighten alarm wiring according Single Phase AC Loss Wiring below.

4.17.2 Single Phase AC Loss Wiring

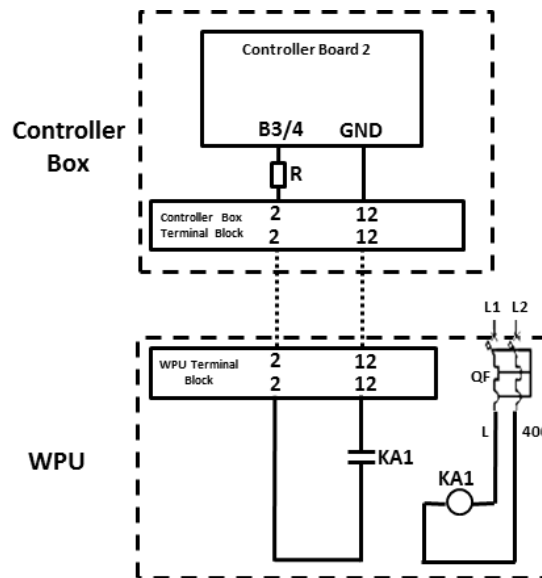

4.17.3 Three Phase AC Loss Troubleshooting

Possible Cause	Component to Check	Recommended Action
AC Loss	AC Breaker on units	Turn on breaker and make sure prime power is present to the unit
Alarm present in Power/Phase Monitor	Power/Phase Monitor (FV). Only the "Normal" LED should be lit.	<ul style="list-style-type: none"> • >U/<U LED indicate the voltage is outside the acceptable range (187-252V) • Phs. Seq. LED indicate the phase sequence must be corrected • Asm LED indicate the phases need to be balanced
Loose/incorrect alarm wire	Alarm wiring	Verify/tighten alarm wiring according Three Phase AC Loss Wiring below.

4.17.4 Three Phase AC Loss Wiring

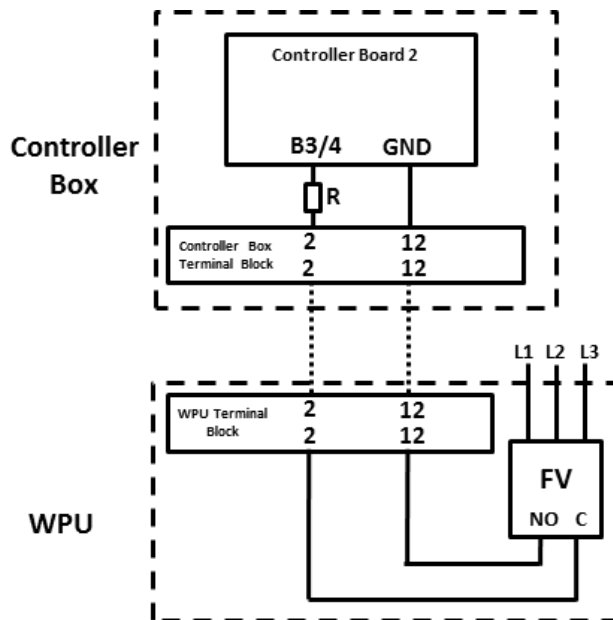

5 SYMPTOMS WITH NO ALARMS

5.1 System function

In some cases, such as incorrect/loose alarm wiring, system symptoms can exist with no active alarm.

Use the step test and test all system functions. If certain function does not work properly, the troubleshooting sections outlined below can be used to troubleshooting these components.

Component not working properly	Refer to section
Supply fan	AC Fan: A10/A11 Evap. Fan OL DC Fan: A29/A30 DC Fan Air Flow Alarm
Heater	A08: Low Temp Alarm
Compressor	A07: High Temp Alarm
Damper	A24/25 Damper Alarm

5.2 No Controller Display

Possible Cause	Component to Check	Recommended Action
Loose display connector	Display connector (white connector on the J7 terminal)	Apply force to push in connector firmly on both ends .
Display safety trip	Overvoltage over normal or generator operation	Reset controller power. If issue persist regularly, verify generator voltage: 187-252VAC
No power to controller	Power Supply LED/ J1 connector	Verify 24VDC Power supply across J1connector (orange). If LED is still dark after DC power is verified and no physical damage on J1 connector, replace the controller.

5.2.1 Controller Power Supply LED

